



HEAVY DUTY SYSTEMS

# REFRIGERATION EQUIPMENT

American Style Products





# Contents

Reach-in Series	3-6
Refrigerated Salad/Sandwich Prep Table	7-10
Refrigerated Pizza Prep Table	11
Chef Base Refrigerator	12
Undercounter Cooler/Freezer	13-14
Work Top Cooler/Freezer	15-16
Backbar Cooler/Beer Dispenser	17-22
Horizontal Bottle Cooler	23
Glass Froster	24
Refrigerated Deli Case	25
Merchandiser Refrigerator	26-28
Merchandiser Freezer	29-30
Refrigerated Cake Display Case	31-32
Milk Cooler	33
Outdoor Rated Small Refrigerator	34
Countertop Merchandiser	35
Dipping Cabinet	36
Refrigerated Bakery Case with Curved Glass	37
Plan View	38-56

# Reach-in Solid Door Refrigerator



- **Stainless steel interior and exterior, aluminum back.**  
Option of bright white aluminum interior available.
- **Refrigeration system** keeps food at safe temperatures between 33°F and 41°F (0.5°C to 5°C).
- **Self-Closing doors** with 90 degree stay-open feature. Locks and keys included.
- **Shelves:** Adjustable heavy-duty PVC coated shelves.
- **Preinstalled heavy-duty casters with brakes.**
- **Electronic control system** makes it easy to adjust temperature set point and defrost frequency.
- **Removable installation board** makes it easy to access condenser coil for cleaning and service.
- **Option of different handles available.**
- **These units use HYDRO-CARBON R290 refrigerant,** which is environmentally friendly and more efficient than R134a/R404a refrigerant.



**HDSR-1S**



**HDSR-2S**



**HDSR-3S**

MODEL	DOORS	SHELVES	DIMENSIONS - WxDxH		CAPACITY	HP	AMPS	VOLTAGE	PLUG TYPE
			inches	mm					
<b>HDSR-1S</b>	1	3	29 x 32 1/4 x 82 1/2	736 x 818 x 2095	23 650	1/5	2.6	115/60/1	NEMA 5-15P
<b>HDSR-2S</b>	2	6	54 x 32 1/4 x 82 1/2	1371 x 818 x 2095	47 1321	1/4+	3.8	115/60/1	NEMA 5-15P
<b>HDSR-3S</b>	3	9	80 9/10 x 32 1/4 x 82 1/2	2054 x 818 x 2095	72 2040	3/4	9	115/60/1	NEMA 5-15P

Specifications subject to change without notice.  
Voltage 220/50/1 available.  
Plug type varies by country.



HEAVY DUTY SYSTEMS  
Add : 143 West 29th Street, New York, NY 10001  
Tel : 212.924.6920 Fax : 212.627.1759 E-mail : sales@heavydutysys.com

# Reach-in Solid Door Freezer



- **Stainless steel interior and exterior, aluminum back.**  
Option of bright white aluminum interior available.
- **Refrigeration system** keeps food at safe temperatures between -8°F and 0°F (-22 °C to -18 °C).
- **Self-Closing doors** with 90 degree stay-open feature. Locks and keys included.
- **Shelves:** Adjustable heavy-duty PVC coated shelves.
- **Preinstalled heavy-duty casters with brakes.**
- **Electronic control system** makes it easy to adjust temperature set point and defrost frequency.
- **Removable installation board** makes it easy to access condenser coil for cleaning and service.
- **Option of different handles available.**
- **These units use HYDRO-CARBON R290 refrigerant,** which is environmentally friendly and more efficient than R134a/R404a refrigerant.



**HDSF-1S**

**HDSF-2S**

**HDSF-3S**

MODEL	DOORS	SHELVES	DIMENSIONS - WxDxH		CAPACITY	HP	AMPS	VOLTAGE	PLUG TYPE
			inches	mm					
<b>HDSF-1S</b>	1	3	29 x 32 1/4 x 82 1/2	736 x 818 x 2095	23 650	1/2+	7.1	115/60/1	NEMA 5-15P
<b>HDSF-2S</b>	2	6	54 x 32 1/4 x 82 1/2	1371 x 818 x 2095	47 1321	1	10.7	115/60/1	NEMA 5-20P
<b>HDSF-3S</b>	3	9	80 9/10 x 32 1/4 x 82 1/2	2054 x 818 x 2095	72 2040	1 1/4	12	115/60/1	NEMA 5-20P

Specifications subject to change without notice.  
Voltage 220/50/1 available.  
Plug type varies by country.



HEAVY DUTY SYSTEMS  
Add : 143 West 29th Street, New York, NY 10001  
Tel : 212.924.6920 Fax : 212.627.1759 E-mail : sales@heavydutysys.com

# Economic Reach-in Refrigerator & Freezer



- **Stainless steel door and exterior sides, aluminum back. Bright white aluminum interior.**
- **Refrigeration system** keeps food at safe temperatures :  
HDSR-19--between 33°F and 41°F(0.5°C to 5°C)  
HDSF-19--between -8°F and 0°F(-17°C to -22°C)
- **Self-Closing doors** with 90 degree stay-open feature.
- **Locks and keys included.**
- **Shelves:** Adjustable heavy PVC coated shelves.
- **Preinstalled heavy-duty casters with brakes.**

- **Electronic control system** makes it easy to adjust temperature set point and defrost frequency.
- **Removable installation board** makes it easy to access condenser coil for cleaning and service.
- **These units use HYDRO-CARBON R290 refrigerant,** which is environmentally friendly and more efficient than R134a/R404a refrigerant.



**HDSR-19**



**HDSF-19**

MODEL	TEMP	SHELVES	DIMENSIONS - WxDxH		CAPACITY	HP	AMPS	VOLTAGE	PLUG TYPE
			inches	mm					
<b>HDSR-19</b>	33°F ~ 41°F	3	29 x 25 3/8 x 82 1/2	736 x 645 x 2095	19 538	1/5	2.8	115/60/1	NEMA 5-15P
<b>HDSF-19</b>	-8°F ~ 0°F	3	29 x 25 3/8 x 82 1/2	736 x 645 x 2095	19 538	1/2+	8.28	115/60/1	NEMA 5-15P

Specifications subject to change without notice.  
Voltage 220/50/1 available.  
Plug type varies by country.



HEAVY DUTY SYSTEMS  
Add : 143 West 29th Street, New York, NY 10001  
Tel : 212.924.6920 Fax : 212.627.1759 E-mail : sales@heavydutysys.com

# Reach-in Glass Door Refrigerator

- **Stainless steel interior and exterior, aluminum back.**  
Option of bright white aluminum interior available.
- **Refrigeration system** keeps food at safe temperatures between 33°F and 41°F (0.5°C to 5°C).
- **Self-Closing glass doors with locks and keys.**
- **Shelves:** Adjustable heavy-duty PVC coated shelves.
- **Preinstalled heavy-duty casters with brakes.**
- **Electronic control system** makes it easy to adjust temperature set point and defrost frequency.
- **Removable installation board** makes it easy to access condenser coil for cleaning and service.
- **Option of different handles available.**
- **These units use HYDRO-CARBON R290 refrigerant,** which is environmentally friendly and more efficient than R134a/R404a refrigerant.



**HDSR-1G**



**HDSR-2G**



**HDSR-3G**

MODEL	DOORS	SHELVES	DIMENSIONS - WxDxH		CAPACITY	HP	AMPS	VOLTAGE	PLUG TYPE
			inches	mm					
<b>HDSR-1G</b>	1	3	29 x 32 1/4 x 82 1/2	736 x 818 x 2095	23 650	1/5	2.6	115/60/1	NEMA 5-15P
<b>HDSR-2G</b>	2	6	54 x 32 1/4 x 82 1/2	1371 x 818 x 2095	47 1321	1/4+	4.3	115/60/1	NEMA 5-15P
<b>HDSR-3G</b>	3	9	80 9/10 x 32 1/4 x 82 1/2	2054 x 818 x 2095	72 2040	3/4	9.1	115/60/1	NEMA 5-15P

Specifications subject to change without notice.  
Voltage 220/50/1 available.  
Plug type varies by country.



HEAVY DUTY SYSTEMS  
Add : 143 West 29th Street, New York, NY 10001  
Tel : 212.924.6920 Fax : 212.627.1759 E-mail : sales@heavydutysys.com

# Sandwich/Salad Prep Table



- **Stainless steel interior and exterior, aluminum back.**  
Option of bright white aluminum interior available.
- **Refrigeration system** keeps food at safe temperatures between 33°F and 41°F (0.5°C to 5°C).
- **Self-Closing doors** with 90 degree stay-open feature.
- **Shelves:** Adjustable heavy-duty PVC coated shelves.
- **Preinstalled heavy-duty casters with brakes.**
- **Option of different handles available.**
- **Electronic control system** makes it easy to adjust temperature set point and defrost frequency.
- **Removable installation board** makes it easy to access condenser coil for cleaning and service.
- **Cutting board thickness :**  
20MM – Exterior/Interior SS304 or Exterior SS430/Interior SS304  
15MM- Exterior SS430/Interior painted aluminum
- **These units use HYDRO-CARBON R290 refrigerant,** which is environmentally friendly and more efficient than R134a/R404a refrigerant.



**HDSSP-1S-28-8**



**HDSSP-2S-36-10**



**HDSSP-2S-47-12**

MODEL	DOORS	SHELVES	PAN LAYOUT	DIMENSIONS - WxDxH		CAPACITY		HP	AMPS	VOLTAGE	PLUG TYPE
				inches	mm	cu.ft.	liters				
<b>HDSSP-1S-28-8</b>	1	1	6x1/6 + 2x1/9	27 1/2 x 29 1/2 x 42 3/8	698 x 750 x 1075	5.7	160	1/5	2.88	115/60/1	NEMA 5-15P
<b>HDSSP-2S-36-10</b>	2	2	10x1/6	36 1/4 x 29 1/2 x 42 3/8	920 x 750 x 1075	7.6	213	1/5	3.24	115/60/1	NEMA 5-15P
<b>HDSSP-2S-47-12</b>	2	2	12x1/6	46 7/8 x 29 1/2 x 42 3/8	1188 x 750 x 1075	9.5	268	1/4+	4.56	115/60/1	NEMA 5-15P

Specifications subject to change without notice.  
Voltage 220/50/1 available.  
Plug type varies by country.



HEAVY DUTY SYSTEMS  
Add : 143 West 29th Street, New York, NY 10001  
Tel : 212.924.6920 Fax : 212.627.1759 E-mail : sales@heavydutysys.com



# Sandwich/Salad Prep Table



- **Stainless steel interior and exterior, aluminum back.**  
Option of bright white aluminum interior available.
- **Refrigeration system** keeps food at safe temperatures between 33°F and 41°F (0.5°C to 5°C).
- **Self-Closing doors** with 90 degree stay-open feature.
- **Shelves:** Adjustable heavy-duty PVC coated shelves.
- **Preinstalled heavy-duty casters with brakes.**
- **Option of different handles available.**
- **Electronic control system** makes it easy to adjust temperature set point and defrost frequency.
- **Removable installation board** makes it easy to access condenser coil for cleaning and service.
- **Cutting board thickness :**  
20MM – Exterior/Interior SS304 or Exterior SS430/Interior SS304  
15MM- Exterior SS430/Interior painted aluminum
- **These units use HYDRO-CARBON R290 refrigerant,** which is environmentally friendly and more efficient than R134a/R404a refrigerant.



**HDSSP-2S-60-16**



**HDSSP-3S-70-18**

MODEL	DOORS	SHELVES	PAN LAYOUT	DIMENSIONS - WxDxH		CAPACITY	HP	AMPS	VOLTAGE	PLUG TYPE
				inches	mm					
<b>HDSSP-2S-60-16</b>	2	2	16x1/6	60 1/5 x 29 1/2 x 42 3/8	1529 x 750 x 1075	15 428	1/4+	4.8	115/60/1	NEMA 5-15P
<b>HDSSP-3S-70-18</b>	3	3	18X1/6	70 2/5 x 29 1/2 x 42 3/8	1787 x 750 x 1075	15.5 440	3/4	8.9	115/60/1	NEMA 5-15P

Specifications subject to change without notice.  
Voltage 220/50/1 available.  
Plug type varies by country.



HEAVY DUTY SYSTEMS  
Add : 143 West 29th Street, New York, NY 10001  
Tel : 212.924.6920 Fax : 212.627.1759 E-mail : sales@heavydutysys.com

# Mega Top Sandwich/Salad Prep Table



- **Stainless steel interior and exterior, aluminum back.**  
Option of bright white aluminum interior available.
- **Refrigeration system** keeps food at safe temperatures between 33°F and 41°F (0.5°C to 5°C).
- **Self-Closing doors** with 90 degree stay-open feature.
- **Shelves:** Adjustable heavy-duty PVC coated shelves.
- **Preinstalled heavy-duty casters with brakes.**
- **Option of different handles available.**
- **Electronic control system** makes it easy to adjust temperature set point and defrost frequency.
- **Removable installation board** makes it easy to access condenser coil for cleaning and service.
- **Cutting board thickness :**  
20MM – Exterior/Interior SS304 or Exterior SS430/Interior SS304  
15MM- Exterior SS430/Interior painted aluminum
- **These units use HYDRO-CARBON R290 refrigerant,** which is environmentally friendly and more efficient than R134a/R404a refrigerant.



**HDSSPM-1S-28-12**



**HDSSPM-2S-36-15**



**HDSSPM-2S-47-18**

MODEL	DOORS	SHELVES	PAN LAYOUT	DIMENSIONS - WxDxH		CAPACITY		HP	AMPS	VOLTAGE	PLUG TYPE
				inches	mm	cu.ft.	liters				
<b>HDSSPM-1S-28-12</b>	1	1	9x1/6 + 3x1/9	27 1/2 x 34 x 45 9/10	698 x 864 x 1166	5.7	160	1/5	2.88	115/60/1	NEMA 5-15P
<b>HDSSPM-2S-36-15</b>	2	2	15x1/6	36 1/4 x 34 x 45 9/10	920 x 864 x 1166	7.6	213	1/5	3.24	115/60/1	NEMA 5-15P
<b>HDSSPM-2S-47-18</b>	2	2	18x1/6	46 7/8 x 34 x 45 9/10	1188 x 864 x 1166	9.5	268	1/4+	4.56	115/60/1	NEMA 5-15P

Specifications subject to change without notice.  
Voltage 220/50/1 available.  
Plug type varies by country.



HEAVY DUTY SYSTEMS  
Add : 143 West 29th Street, New York, NY 10001  
Tel : 212.924.6920 Fax : 212.627.1759 E-mail : sales@heavydutysys.com

# Mega Top Sandwich/Salad Prep Table

- **Stainless steel interior and exterior, aluminum back.**  
Option of bright white aluminum interior available.
- **Refrigeration system** keeps food at safe temperatures between 33°F and 41°F (0.5°C to 5°C).
- **Self-Closing doors** with 90 degree stay-open feature.
- **Shelves:** Adjustable heavy-duty PVC coated shelves.
- **Preinstalled heavy-duty casters with brakes.**
- **Option of different handles available.**
- **Electronic control system** makes it easy to adjust temperature set point and defrost frequency.
- **Removable installation board** makes it easy to access condenser coil for cleaning and service.
- **Cutting board thickness :**  
20MM – Exterior/Interior SS304 or Exterior SS430/Interior SS304  
15MM- Exterior SS430/Interior painted aluminum
- **These units use HYDRO-CARBON R290 refrigerant,** which is environmentally friendly and more efficient than R134a/R404a refrigerant.



**HDSSPM-2S-60-24**



**HDSSPM-3S-70-30**

MODEL	DOORS	SHELVES	PAN LAYOUT	DIMENSIONS - WxDxH		CAPACITY		HP	AMPS	VOLTAGE	PLUG TYPE
				inches	mm	cu.ft.	liters				
<b>HDSSPM-2S-60-24</b>	2	2	24x1/6	60 1/5 x 34 x 45 9/10	1529 x 864 x 1166	15	428	1/4+	4.8	115/60/1	NEMA 5-15P
<b>HDSSPM-3S-70-30</b>	3	3	30x1/6	70 2/5 x 34 x 45 9/10	1787 x 864 x 1166	15.5	440	3/4	8.9	115/60/1	NEMA 5-15P

Specifications subject to change without notice.  
Voltage 220/50/1 available.  
Plug type varies by country.



HEAVY DUTY SYSTEMS  
Add : 143 West 29th Street, New York, NY 10001  
Tel : 212.924.6920 Fax : 212.627.1759 E-mail : sales@heavydutysys.com

# Pizza Prep Table



- **Stainless steel interior and exterior ,aluminum back.**  
Option of bright white aluminum interior available .
- **Refrigeration system** keeps food at safe temperatures between 33°F and 41°F (0.5°C to 5°C).
- **Self-Closing doors** with 90 degree stay-open feature.
- **Shelves:** Adjustable heavy-duty PVC coated shelves.
- **Preinstalled heavy-duty casters with brakes.**
- **Option of different handles available.**
- **Electronic control system** makes it easy to adjust temperature set point and defrost frequency.
- **Removable installation board** makes it easy to access condenser coil for cleaning and service.
- **Cutting board thickness :**  
20MM – Exterior/Interior SS304 or Exterior SS430/Interior SS304  
15MM- Exterior SS430/Interior painted aluminum
- **These units use HYDRO-CARBON R290 refrigerant,** which is environmentally friendly and more efficient than R134a/R404a refrigerant.



**HDSPP-1-50-6**



**HDSPP-2-71-9**



**HDSPP-3-92-12**

MODEL	DOORS	SHELVES	PAN LAYOUT	DIMENSIONS - WxDxH		CAPACITY	HP	AMPS	VOLTAGE	PLUG TYPE
				inches	mm					
<b>HDSPP-1-50-6</b>	1	1	6x1/3	49 7/8 x 31 1/2 x 42 7/8	1266 x 800 x 1088	13.8 391	1/6	2.64	115/60/1	NEMA 5-15P
<b>HDSPP-2-71-9</b>	2	2	9X1/3	70 9/10 x 31 1/2 x 42 7/8	1800 x 800 x 1088	16.9 477	1/5	3.42	115/60/1	NEMA 5-15P
<b>HDSPP-3-92-12</b>	3	3	12X1/3	91 9/10 x 31 1/2 x 42	2334 x 800 x 1088	24.2 684	1/4+	5.28	115/60/1	NEMA 5-15P

Specifications subject to change without notice.  
Voltage 220/50/1 available.  
Plug type varies by country.



HEAVY DUTY SYSTEMS  
Add : 143 West 29th Street, New York, NY 10001  
Tel : 212.924.6920 Fax : 212.627.1759 E-mail : sales@heavydutysys.com

# Chef Base Refrigerator



- **Stainless steel interior and exterior** retains attractive finish longer. Matching aluminum finished back.
- **Stainless steel top equipped with a marine edge** enables the unit's top to contain drips and spills for easy cleanup.
- **Refrigeration system** keeps food at safe temperatures between 33°F and 41°F (0.5°C to 5°C).
- **Preinstalled heavy-duty casters with brakes.**
- **Electronic control system** makes it easy to adjust temperature set point and defrost frequency.
- **Removable installation board** makes it easy to access condenser coil for cleaning and service.
- **Heavy-duty pull handles.**
- **These units use HYDRO-CARBON R290 refrigerant,** which is environmentally friendly and more efficient than R134a/R404a refrigerant.



**HDSCB-36-2**



**HDSCB-52-2**



**HDSCB-72-4**

MODEL	DRAWERS	GN PANS	DIMENSIONS - WxDxH		CAPACITY	HP	AMPS	VOLTAGE	PLUG TYPE
			inches	mm					
<b>HDSCB-36-2</b>	2	2*1/1+6*1/6	36 3/8 x 32 1/8 x 25 3/8	924 x 816 x 645	5.9 167	1/6	2.52	115/60/1	NEMA 5-15P
<b>HDSCB-52-2</b>	2	6*1/1	51 7/8 x 32 1/8 x 25 3/8	1318 x 816 x 645	9.9 280	1/6	3.48	115/60/1	NEMA 5-15P
<b>HDSCB-72-4</b>	4	8*1/1	72 3/8 x 32 1/8 x 25 5/8	1839 x 816 x 645	15 425	1/5	4.68	115/60/1	NEMA 5-15P

Specifications subject to change without notice.  
Voltage 220/50/1 available.  
Plug type varies by country.



HEAVY DUTY SYSTEMS  
Add : 143 West 29th Street, New York, NY 10001  
Tel : 212.924.6920 Fax : 212.627.1759 E-mail : sales@heavydutysys.com

# Undercounter Refrigerator



- **Stainless steel interior and exterior, aluminum back.**  
Option of bright white aluminum interior available.
- **Refrigeration system** keeps food at safe temperatures between 33°F and 41°F (0.5°C to 5°C).
- **Self-Closing doors** with 90 degree stay-open feature.
- **Shelves:** Adjustable heavy-duty PVC coated shelves.
- Option of **Backsplashes** available.
- **Preinstalled heavy-duty casters with brakes.**
- **Electronic control system** makes it easy to adjust temperature set point and defrost frequency.
- **Removable installation board** makes it easy to access condenser coil for cleaning and service.
- **Option of different handles available.**
- **These units use HYDRO-CARBON R290 refrigerant,** which is environmentally friendly and more efficient than R134a/R404a refrigerant.



**HDSUCR-1S-27**



**HDSUCR-2S-47**  
**HDSUCR-2S-60**



**HDSUCR-3S-72**

MODEL	DOORS	SHELVES	DIMENSIONS - WxDxH		CAPACITY	HP	AMPS	VOLTAGE	PLUG TYPE
			inches	mm					
<b>HDSUCR-1S-27</b>	1	1	27 x 29 1/2 x 35 1/5 685 x 750 x 895		6.3 177	1/6	1.9	115/60/1	NEMA 5-15P
<b>HDSUCR-2S-47</b>	2	2	47 1/5 x 29 1/2 x 35 1/5 1200 x 750 x 895		12 338	1/5	2.7	115/60/1	NEMA 5-15P
<b>HDSUCR-2S-60</b>	2	2	60 1/5 x 29 1/2 x 35 1/5 1526 x 750 x 895		15 428	1/5	2.9	115/60/1	NEMA 5-15P
<b>HDSUCR-3S-72</b>	3	3	72 x 29 1/2 x 35 1/5 1829 x 750 x 895		15.5 440	1/5	3.2	115/60/1	NEMA 5-15P

Specifications subject to change without notice.  
Voltage 220/50/1 available.  
Plug type varies by country.



HEAVY DUTY SYSTEMS  
Add : 143 West 29th Street, New York, NY 10001  
Tel : 212.924.6920 Fax : 212.627.1759 E-mail : sales@heavydutysys.com

# Undercounter Freezer



- **Stainless steel interior and exterior, aluminum back.**  
Option of bright white aluminum interior available.
- **Refrigeration system** keeps food at safe temperatures between -8°F and 0°F (-22°C to -18°C).
- **Self-Closing doors** with 90 degree stay-open feature.
- **Shelves:** Adjustable heavy-duty PVC coated shelves.
- Option of **Backsplashes** available.
- **Preinstalled heavy-duty casters with brakes.**
- **Electronic control system** makes it easy to adjust temperature set point and defrost frequency.
- **Removable installation board** makes it easy to access condenser coil for cleaning and service.
- Option of different handles available.
- **These units use HYDRO-CARBON R290 refrigerant,** which is environmentally friendly and more efficient than R134a/R404a refrigerant.



**HDSUCF-1S-27**



**HDSUCF-2S-47**



**HDSUCF-2S-60**

MODEL	DOORS	SHELVES	DIMENSIONS - WxDxH		CAPACITY	HP	AMPS	VOLTAGE	PLUG TYPE
			inches	mm					
<b>HDSUCF-1S-27</b>	1	1	27 x 29 1/2 x 35 1/5 685 x 750 x 895		6.3 177	1/5	2.1	115/60/1	NEMA 5-15P
<b>HDSUCF-2S-47</b>	2	2	47 1/5 x 29 1/2 x 35 1/5 1200 x 750 x 895		12 338	1/4+	4.5	115/60/1	NEMA 5-15P
<b>HDSUCF-2S-60</b>	2	2	60 1/5 x 29 1/2 x 35 1/5 1526 x 750 x 895		15 428	1/2+	6.36	115/60/1	NEMA 5-15P

Specifications subject to change without notice.  
Voltage 220/50/1 available.  
Plug type varies by country.



HEAVY DUTY SYSTEMS  
Add : 143 West 29th Street, New York, NY 10001  
Tel : 212.924.6920 Fax : 212.627.1759 E-mail : sales@heavydutysys.com

# Worktop Refrigerator



- **Stainless steel interior and exterior, aluminum back.**  
Option of bright white aluminum interior available.
- **Refrigeration system** keeps food at safe temperatures between 33°F and 41°F (0.5°C to 5°C).
- **Self-Closing doors** with 90 degree stay-open feature.
- **Shelves:** Adjustable heavy-duty PVC coated shelves.
- **Preinstalled heavy-duty casters with brakes.**
- **Electronic control system** makes it easy to adjust temperature set point and defrost frequency.
- **Removable installation board** makes it easy to access condenser coil for cleaning and service.
- **Option of different handles available.**
- **These units use HYDRO-CARBON R290 refrigerant,** which is environmentally friendly and more efficient than R134a/R404a refrigerant.



**HDSWTR-1S-27**



**HDSWTR-2S-47**  
**HDSWTR-2S-60**



**HDSWTR-3S-72**

MODEL	DOORS	SHELVES	DIMENSIONS - WxDxH		CAPACITY	HP	AMPS	VOLTAGE	PLUG TYPE
			inches	mm					
<b>HDSWTR-1S-27</b>	1	1	27 x 29 1/2 x 38 3/4	685 x 750 x 984	6.3 177	1/6	1.9	115/60/1	NEMA 5-15P
<b>HDSWTR-2S-47</b>	2	2	47 1/5 x 29 1/2 x 38 3/4	1200 x 750 x 984	12 338	1/5	2.7	115/60/1	NEMA 5-15P
<b>HDSWTR-2S-60</b>	2	2	60 1/5 x 29 1/2 x 38 3/4	1526 x 750 x 984	15 428	1/5	2.9	115/60/1	NEMA 5-15P
<b>HDSWTR-3S-72</b>	3	3	72 x 29 1/2 x 38 3/4	1829 x 750 x 984	15.5 440	1/5	3.2	115/60/1	NEMA 5-15P

Specifications subject to change without notice.  
Voltage 220/50/1 available.  
Plug type varies by country.



HEAVY DUTY SYSTEMS  
Add : 143 West 29th Street, New York, NY 10001  
Tel : 212.924.6920 Fax : 212.627.1759 E-mail : sales@heavydutysys.com



# Worktop Freezer



- **Stainless steel interior and exterior, aluminum back.**  
Option of bright white aluminum interior available.
- **Refrigeration system** keeps food at safe temperatures between -8°F and 0°F (-22°C to -18°C).
- **Self-Closing doors** with 90 degree stay-open feature.
- **Shelves:** Adjustable heavy-duty PVC coated shelves.
- **Preinstalled heavy-duty casters with brakes.**
- **Electronic control system** makes it easy to adjust temperature set point and defrost frequency.
- **Removable installation board** makes it easy to access condenser coil for cleaning and service.
- **Option of different handles available.**
- **These units use HYDRO-CARBON R290 refrigerant,** which is environmentally friendly and more efficient than R134a/R404a refrigerant.



**HDSWTF-1S-27**



**HDSWTF-2S-47**



**HDSWTF-2S-60**

MODEL	DOORS	SHELVES	DIMENSIONS - WxDxH		CAPACITY	HP	AMPS	VOLTAGE	PLUG TYPE
			inches	mm					
<b>HDSWTF-1S-27</b>	1	1	27 x 29 1/2 x 38 3/4	685 x 750 x 984	6.3 177	1/5	2.1	115/60/1	NEMA 5-15P
<b>HDSWTF-2S-47</b>	2	2	47 1/5 x 29 1/2 x 38 3/4	1200 x 750 x 984	12 338	1/4+	4.5	115/60/1	NEMA 5-15P
<b>HDSWTF-2S-60</b>	2	2	60 1/5 x 29 1/2 x 38 3/4	1526 x 750 x 984	15 428	1/2+	6.36	115/60/1	NEMA 5-15P

Specifications subject to change without notice.  
Voltage 220/50/1 available.  
Plug type varies by country.



HEAVY DUTY SYSTEMS  
Add : 143 West 29th Street, New York, NY 10001  
Tel : 212.924.6920 Fax : 212.627.1759 E-mail : sales@heavydutysys.com

# Back Bar Cooler - 24" Depth Glass Door Series



- **Durable stainless steel top, interior walls, floor and ceiling.**
- **Exterior construction** is attractive corrosion resistant vinyl on steel in black finish.
- **Refrigeration system** keeps the drinks at safe temperatures between 33°F and 41°F (0.5°C to 5°C).
- **Electronic control system** makes it easy to adjust temperature set point and defrost frequency.
- **Shelves:** Adjustable heavy-duty PVC coated shelves.
- **Option of stainless steel exterior available.**
- **Preinstalled heavy-duty casters with brakes.**  
Option of leveling feet available.
- **Self-Closing doors with locks.**
- **LED interior lighting.**
- **Removable installation board** makes it easy to access condenser coil for cleaning and service.
- **These units use HYDRO-CARBON R290 refrigerant,** which is environmentally friendly and more efficient than R134a/R404a refrigerant.



**HDSBB-24-48G**



**HDSBB-24-60G**



**HDSBB-24-72G**

MODEL	DOORS	SHELVES	DIMENSIONS - WxDxH		CAPACITY	HP	AMPS	VOLTAGE	PLUG TYPE
			inches	mm					
<b>HDSBB-24-48G</b>	2	4	48 7/8 x 24 3/8 x 35 5/8	1240 x 620 x 905	11.8 335	1/5	2.88	115/60/1	NEMA 5-15P
<b>HDSBB-24-60G</b>	2	4	60 3/4 x 24 3/8 x 35 5/8	1544 x 620 x 905	15.8 446	1/5	2.88	115/60/1	NEMA 5-15P
<b>HDSBB-24-72G</b>	3	6	72 3/4 x 24 3/8 x 35 5/8	1848 x 620 x 905	19.6 556	1/4+	3.96	115/60/1	NEMA 5-15P

Specifications subject to change without notice.  
Voltage 220/50/1 available.  
Plug type varies by country.



HEAVY DUTY SYSTEMS  
Add : 143 West 29th Street, New York, NY 10001  
Tel : 212.924.6920 Fax : 212.627.1759 E-mail : sales@heavydutysys.com

# Back Bar Cooler - 24" Depth Solid Door Series



- **Durable stainless steel top, interior walls, floor and ceiling.**
- **Exterior construction** is attractive corrosion resistant vinyl on steel in black finish.
- **Refrigeration system** keeps the drinks at safe temperatures between 33°F and 41°F (0.5°C to 5°C).
- **Electronic control system** makes it easy to adjust temperature set point and defrost frequency.
- **Shelves:** Adjustable heavy-duty PVC coated shelves.
- **Option of stainless steel exterior available.**
- **Preinstalled heavy-duty casters with brakes.**  
Option of leveling feet available.
- **Self-Closing doors with locks.**
- **LED interior lighting.**
- **Removable installation board** makes it easy to access condenser coil for cleaning and service.
- **These units use HYDRO-CARBON R290 refrigerant,** which is environmentally friendly and more efficient than R134a/R404a refrigerant.



**HDSBB-24-48S**



**HDSBB-24-60S**



**HDSBB-24-72S**

MODEL	DOORS	SHELVES	DIMENSIONS - WxDxH		CAPACITY	HP	AMPS	VOLTAGE	PLUG TYPE
			inches	mm					
<b>HDSBB-24-48S</b>	2	4	48 7/8 x 24 3/8 x 35 5/8	1240 x 620 x 905	11.8 335	1/5	2.88	115/60/1	NEMA 5-15P
<b>HDSBB-24-60S</b>	2	4	60 3/4 x 24 3/8 x 35	1544 x 620 x 905	15.8 446	1/5	2.88	115/60/1	NEMA 5-15P
<b>HDSBB-24-72S</b>	3	6	72 3/4 x 24 3/8 x 35 5/8	1848 x 620 x 905	19.6 556	1/4	3.96	115/60/1	NEMA 5-15P

Specifications subject to change without notice.  
Voltage 220/50/1 available.  
Plug type varies by country.



HEAVY DUTY SYSTEMS  
Add : 143 West 29th Street, New York, NY 10001  
Tel : 212.924.6920 Fax : 212.627.1759 E-mail : sales@heavydutysys.com

# Direct Draw Beer Dispenser - 24" Depth Series



- **Durable stainless steel top, interior walls, floor and ceiling.**
- **Exterior construction** is attractive corrosion resistant vinyl on steel in black finish.
- **Refrigeration system** keeps the drinks at safe temperatures between 33°F and 41°F (0.5°C to 5°C).
- **Electronic control system** makes it easy to adjust temperature set point and defrost frequency.
- **Shelves:** Adjustable heavy-duty PVC coated shelves.
- **Option of stainless steel exterior available.**
- **Preinstalled heavy-duty casters with brakes.**  
Option of leveling feet available.
- **Self-Closing doors with locks.**
- **LED interior lighting.**
- **Removable installation board** makes it easy to access condenser coil for cleaning and service.
- **These units use HYDRO-CARBON R290 refrigerant,** which is environmentally friendly and more efficient than R134a/R404a refrigerant.



**HDSDD-24-48**



**HDSDD-24-60**



**HDSDD-24-72**

MODEL	DOORS	SHELVES	DIMENSIONS - WxDxH		CAPACITY cu.ft. barrels	HP	AMPS	VOLTAGE	PLUG TYPE
			inches	mm					
<b>HDSDD-24-48</b>	2	4	48 7/8 x 24 3/8 x 35 5/8 1240 x 620 x 905		11.8 2*1/2	1/5	3	115/60/1	NEMA 5-15P
<b>HDSDD-24-60</b>	2	4	60 3/4 x 24 3/8 x 35 5/8 1544 x 620 x 905		15.8 2*1/2	1/5	3	115/60/1	NEMA 5-15P
<b>HDSDD-24-72</b>	3	6	72 3/4 x 24 3/8 x 35 5/8 1848 x 620 x 905		19.6 3*1/2	1/4+	4	115/60/1	NEMA 5-15P

\* Height does not include 15.8"(402mm) for draft arm.

Specifications subject to change without notice.  
Voltage 220/50/1 available.  
Plug type varies by country.



HEAVY DUTY SYSTEMS  
Add : 143 West 29th Street, New York, NY 10001  
Tel : 212.924.6920 Fax : 212.627.1759 E-mail : sales@heavydutysys.com

# Direct Draw Beer Dispenser - 27" Depth Series



- **Durable stainless steel top, interior walls, floor and ceiling.**
- **Exterior construction** is attractive corrosion resistant vinyl on steel in black finish.
- **Refrigeration system** keeps the drinks at safe temperatures between 33°F and 41°F (0.5°C to 5°C).
- **Electronic control system makes it** easy to adjust temperature set point and defrost frequency.
- **Shelves:** Adjustable heavy-duty PVC coated shelves.
- **Option of stainless steel exterior available.**
- **Preinstalled heavy-duty casters with brakes.**  
Option of leveling feet available.
- **Self-Closing doors with locks.**
- **LED interior lighting.**
- **Removable installation board** makes it easy to access condenser coil for cleaning and service.
- **These units use HYDRO-CARBON R290 refrigerant,** which is environmentally friendly and more efficient than R134a/R404a refrigerant.



**HDSDD-30-23**

**HDSDD-27-58**

**HDSDD-27-69**

**HDSDD-27-90**

MODEL	DOORS	SHELVES	DIMENSIONS - WxDxH		CAPACITY cu.ft. barrels	HP	AMPS	VOLTAGE	PLUG TYPE
			inches	mm					
<b>HDSDD-30-23</b>	1	1	23 1/2 x 30 3/8 x 38 3/4 596 x 772 x 983		6.5 1*1/2	1/6	1.92	115/60/1	NEMA 5-15P
<b>HDSDD-27-58</b>	2	4	58 7/8 x 27 3/4 x 35 5/8 1495 x 705 x 905		19 2*1/2	1/5	2.88	115/60/1	NEMA 5-15P
<b>HDSDD-27-69</b>	2	4	69 1/8 x 27 3/4 x 35 5/8 1755 x 705 x 905		23.3 3*1/2	1/5	3.6	115/60/1	NEMA 5-15P
<b>HDSDD-27-90</b>	3	6	90 3/8 x 27 3/4 x 35 5/8 2295 x 705 x 905		32 4*1/2	1/4+	4.7	115/60/1	NEMA 5-15P

\* Height does not include 15.8"(402mm) for draft arm.

Specifications subject to change without notice.  
Voltage 220/50/1 available.  
Plug type varies by country.



HEAVY DUTY SYSTEMS  
Add : 143 West 29th Street, New York, NY 10001  
Tel : 212.924.6920 Fax : 212.627.1759 E-mail : sales@heavydutysys.com

# Back Bar Cooler - 27" Depth Glass Door Series



- **Durable stainless steel top, interior walls, floor and ceiling.**
- **Exterior construction** is attractive corrosion resistant vinyl on steel in black finish.
- **Refrigeration system** keeps the drinks at safe temperatures between 33°F and 41°F (0.5°C to 5°C).
- **Electronic control system** makes it easy to adjust temperature set point and defrost frequency.
- **Shelves:** Adjustable heavy-duty PVC coated shelves.
- **Option of stainless steel exterior available.**
- **Preinstalled heavy-duty casters with brakes.**  
Option of leveling feet available.
- **Self-Closing doors with locks.**
- **LED interior lighting.**
- **Removable installation board** makes it easy to access condenser coil for cleaning and service.
- **These units use HYDRO-CARBON R290 refrigerant,** which is environmentally friendly and more efficient than R134a/R404a refrigerant.



**HDSBB-30-23G**

**HDSBB-27-58G**

**HDSBB-27-69G**

**HDSBB-27-90G**

MODEL	DOORS	SHELVES	DIMENSIONS - WxDxH		CAPACITY	HP	AMPS	VOLTAGE	PLUG TYPE
			inches	mm					
<b>HDSBB-30-23G</b>	1	1	23 1/2 x 30 3/8 x 38 3/4	596 x 772 x 983	6.5 186	1/6	1.92	115/60/1	NEMA 5-15P
<b>HDSBB-27-58G</b>	2	4	58 7/8 x 27 3/4 x 35 5/8	1495 x 705 x 905	19 546	1/5	2.88	115/60/1	NEMA 5-15P
<b>HDSBB-27-69G</b>	2	4	69 1/8 x 27 3/4 x 35 5/8	1755 x 705 x 905	23.3 666	1/5	3.6	115/60/1	NEMA 5-15P
<b>HDSBB-27-90G</b>	3	6	90 3/8 x 27 3/4 x 35 5/8	2295 x 705 x 905	32 916	1/4+	4.7	115/60/1	NEMA 5-15P

Specifications subject to change without notice.  
Voltage 220/50/1 available.  
Plug type varies by country.



HEAVY DUTY SYSTEMS  
Add : 143 West 29th Street, New York, NY 10001  
Tel : 212.924.6920 Fax : 212.627.1759 E-mail : sales@heavydutysys.com

# Back Bar Cooler - 27" Depth Solid Door Series



- **Durable stainless steel top, interior walls, floor and ceiling.**
- **Exterior construction** is attractive corrosion resistant vinyl on steel in black finish.
- **Refrigeration system** keeps the drinks at safe temperatures between 33°F and 41°F (0.5°C to 5°C).
- **Electronic control system** makes it easy to adjust temperature set point and defrost frequency.
- **Shelves:** Adjustable heavy-duty PVC coated shelves.
- **Option of stainless steel exterior available.**
- **Preinstalled heavy-duty casters with brakes.**  
Option of leveling feet available.
- Self-Closing doors with locks.
- **LED interior lighting.**
- **Removable installation board** makes it easy to access condenser coil for cleaning and service.
- **These units use HYDRO-CARBON R290 refrigerant,** which is environmentally friendly and more efficient than R134a/R404a refrigerant.



**HDSBB-30-23S**

**HDSBB-27-58S**

**HDSBB-27-69S**

**HDSBB-27-90S**

MODEL	DOORS	SHELVES	DIMENSIONS - WxDxH		CAPACITY	HP	AMPS	VOLTAGE	PLUG TYPE
			inches	mm					
<b>HDSBB-30-23S</b>	1	1	23 1/2 x 30 3/8 x 38 3/4	596 x 772 x 983	6.5 186	1/6	1.92	115/60/1	NEMA 5-15P
<b>HDSBB-27-58S</b>	2	4	58 7/8 x 27 3/4 x 35 5/8	1495 x 705 x 905	19 546	1/5	2.88	115/60/1	NEMA 5-15P
<b>HDSBB-27-69S</b>	2	4	69 1/8 x 27 3/4 x 35 5/8	1755 x 705 x 905	23.3 666	1/5	3.6	115/60/1	NEMA 5-15P
<b>HDSBB-27-90S</b>	3	6	90 3/8 x 27 3/4 x 35 5/8	2295 x 705 x 905	32 916	1/4+	4.7	115/60/1	NEMA 5-15P

Specifications subject to change without notice.  
Voltage 220/50/1 available.  
Plug type varies by country.



HEAVY DUTY SYSTEMS  
Add : 143 West 29th Street, New York, NY 10001  
Tel : 212.924.6920 Fax : 212.627.1759 E-mail : sales@heavydutysys.com

# Horizontal Bottle Cooler



- **Durable stainless steel top, interior walls, floor and ceiling.**
- **Exterior construction** is attractive corrosion resistant vinyl on steel in black finish.
- **Refrigeration system** keeps the drinks at safe temperatures between 33°F and 41°F (0.5°C to 3.3°C).
- **Removable bottle cap opener and cap catcher included.**
- **Option of stainless steel exterior available.**
- **Electronic control system** makes it easy to adjust temperature set point and defrost frequency.
- **Removable installation board** makes it easy to access condenser coil for cleaning and service.
- **Adjustable coated-steel dividers included.**
- **These units use HYDRO-CARBON R290 refrigerant,** which is environmentally friendly and more efficient than R134a/R404a refrigerant.



**HDSBC-26**

**HDSBC-49  
HDSBC-64**

**HDSBC-95**

MODEL	LIDS	DIMENSIONS - WxDxH		CAPACITY		HP	AMPS	VOLTAGE	PLUG TYPE
		inches	mm	12 oz. Blts cases	12 oz. Cans cases				
<b>HDSBC-26</b>	1	26 3/8 x 28 3/8 x 34 1/4	670 x 713 x 869	4.5	6	1/6	2.04	115/60/1	NEMA 5-15P
<b>HDSBC-49</b>	2	49 1/2 x 26 5/8 x 34 1/4	1257 x 713 x 869	16.5	24	1/6	2.28	115/60/1	NEMA 5-15P
<b>HDSBC-64</b>	2	64 1/2 x 26 5/8 x 34 1/4	1638 x 713 x 869	22	32	1/6	2.6	115/60/1	NEMA 5-15P
<b>HDSBC-95</b>	3	95 1/5 x 26 5/8 x 34 1/4	2418 x 713 x 869	37.5	55	1/4+	4.2	115/60/1	NEMA 5-15P

Specifications subject to change without notice.  
Voltage 220/50/1 available.  
Plug type varies by country.



HEAVY DUTY SYSTEMS  
Add : 143 West 29th Street, New York, NY 10001  
Tel : 212.924.6920 Fax : 212.627.1759 E-mail : sales@heavydutysys.com



- **Durable stainless steel top, interior walls, floor and ceiling.**
- **Exterior construction** is attractive corrosion resistant vinyl on steel in black finish.
- **Refrigeration system** keeps the glasses/plates at safe temperatures between -5°F and 2°F (-20°C to -16°C).
- **Adjustable coated-steel dividers included.**
- **Option of stainless steel exterior available.**
- **Electronic control system** makes it easy to adjust temperature set point and defrost frequency.
- **Removable installation board** makes it easy to access condenser coil for cleaning and service.
- **These units use HYDRO-CARBON R290 refrigerant,** which is environmentally friendly and more efficient than R134a/R404a refrigerant.



**HDSGF-26**



**HDSGF-49**

MODEL	LIDS	DIMENSIONS - WxDxH		CAPACITY		HP	AMPS	VOLTAGE	PLUG TYPE
		inches	mm	8" (204mm) mugs	10 oz. steins				
<b>HDSGF-26</b>	1	26 3/8 x 26 5/8 x 34 1/4 670 x 677 x 869		90	85	1/5	2.04	115/60/1	NEMA 5-15P
<b>HDSGF-49</b>	2	49 1/2 x 26 5/8 x 34 1/4 1257 x 677 x 869		250	240	1/4+	3	115/60/1	NEMA 5-15P

Specifications subject to change without notice.  
Voltage 220/50/1 available.  
Plug type varies by country.



HEAVY DUTY SYSTEMS  
Add : 143 West 29th Street, New York, NY 10001  
Tel : 212.924.6920 Fax : 212.627.1759 E-mail : sales@heavydutysys.com

# Refrigerated Deli Case



- **Interior:** Aluminum liner with stainless steel floor.
- **Exterior:** Black or white coated steel. Stainless steel available.  
**Attractive curved glass and sliding glass doors.**
- **Rounded corner design** inside of the cabinet makes it easy to clean the inside storage room.
- **Refrigeration system** keeps the meats and deli products at safe temperatures between 32°F and 43°F (0°C to 6°C).
- **Preinstalled heavy-duty casters with brakes.**
- **Electronic control system** makes it easy to adjust temperature set point and defrost frequency.
- **Removable installation board** makes it easy to access condenser coil for cleaning and service.
- **Shelves:** Adjustable heavy-duty PVC coated shelves.
- **LED interior lighting.**
- **These units use HYDRO-CARBON R290 refrigerant,** which is environmentally friendly and more efficient than R134a/R404a refrigerant.



**HDSRDC-36**



**HDSRDC-82**

**HDSRDC-47**

**HDSRDC-64**

MODEL	DOORS	SHELVES	DIMENSIONS - WxDxH		CAPACITY	HP	AMPS	VOLTAGE	PLUG TYPE
			inches	mm					
<b>HDSRDC-36</b>	2	6	36 x 32 1/2 x 42 7/8	920 x 825 x 1089	12 330	1/3	4.68	115/60/1	NEMA 5-15P
<b>HDSRDC-47</b>	2	6	48 x 32 1/2 x 42 7/8	1200 x 825 x 1089	18 508	1/4+	3.12	115/60/1	NEMA 5-15P
<b>HDSRDC-64</b>	3	9	64 x 32 1/2 x 42 7/8	1630 x 825 x 1089	22 620	3/5	7.14	115/60/1	NEMA 5-15P
<b>HDSRDC-82</b>	3	9	82 x 32 1/2 x 42 7/8	2082 x 825 x 1089	32 903	3/4	7.08	115/60/1	NEMA 5-15P

Specifications subject to change without notice.  
Voltage 220/50/1 available.  
Plug type varies by country.



HEAVY DUTY SYSTEMS  
Add : 143 West 29th Street, New York, NY 10001  
Tel : 212.924.6920 Fax : 212.627.1759 E-mail : sales@heavydutysys.com

# Merchandising Swing Glass Door Refrigerator



- **Exterior:** Coated steel. **Black or white finish available.**
- **Interior:** Attractive aluminum liner with stainless steel floor.
- **Refrigeration system** maintains temperatures between 33°F and 41°F(0.5°C to 5°C).
- **Self-Closing double pane glass door with positive seal.**
- **Shelves:** Adjustable heavy-duty PVC coated shelves.
- **Leveling feet or casters are available.**
- **LED lighting.**
- **Electronic control system** makes it easy to adjust temperature set point and defrost frequency.
- **Removable installation board** makes it easy to access condenser coil for cleaning and service.
- **These units use HYDRO-CARBON R290 refrigerant,** which is environmentally friendly and more efficient than R134a/R404a refrigerant.



**HDSMR-21-1**



**HDSMR-25-1**



**HDSMR-28-1**

MODEL	DOORS	SHELVES	DIMENSIONS - WxDxH		CAPACITY cu.ft. liters	HP	AMPS	VOLTAGE	PLUG TYPE
			inches	mm					
<b>HDSMR-21-1</b>	1	4	21 5/8 x 21 5/8 x 63	550 x 550 x 1600	9.1 258	1/5	2.88	115/60/1	NEMA 5-15P
<b>HDSMR-25-1</b>	1	4	25 3/5 x 22 4/5 x 79 3/8	650 x 580 x 2015	14 398	1/5	2.88	115/60/1	NEMA 5-15P
<b>HDSMR-28-1</b>	1	4	28 3/8 x 31 7/8 x 79 3/8	720 x 810 x 2015	23 648	1/5	3	115/60/1	NEMA 5-15P

Specifications subject to change without notice.  
Voltage 220/50/1 available.  
Plug type varies by country.



HEAVY DUTY SYSTEMS  
Add : 143 West 29th Street, New York, NY 10001  
Tel : 212.924.6920 Fax : 212.627.1759 E-mail : sales@heavydutysys.com

# Merchandising Sliding Glass Door Refrigerator



- **Exterior:** Coated steel. **Black or white finish available.**
- **Interior:** Attractive aluminum liner with stainless steel floor.
- **Refrigeration system** maintains temperatures between 33°F and 41°F(0.5°C to 5°C).
- **Self-Closing double pane glass door with positive seal.**
- **Shelves:** Adjustable heavy-duty PVC coated shelves.
- **Leveling feet or casters are available.**
- **LED lighting.**
- **Electronic control system** makes it easy to adjust temperature set point and defrost frequency.
- **Removable installation board** makes it easy to access condenser coil for cleaning and service.
- **These units use HYDRO-CARBON R290 refrigerant,** which is environmentally friendly and more efficient than R134a/R404a refrigerant.



**HDSMR-53-2-Y Black**



**HDSMR-53-2-Y White**

MODEL	DOORS	SHELVES	DIMENSIONS - WxDxH		CAPACITY	HP	AMPS	VOLTAGE	PLUG TYPE
			inches	mm					
<b>HDSMR-53-2-Y</b>	2	8	53 1/8 x 31 7/8 x 79 3/8	1350 x 810 x 2015	45 1270	1/4+	4.3	115/60/1	NEMA 5-15P

Specifications subject to change without notice.  
Voltage 220/50/1 available.  
Plug type varies by country.



HEAVY DUTY SYSTEMS  
Add : 143 West 29th Street, New York, NY 10001  
Tel : 212.924.6920 Fax : 212.627.1759 E-mail : sales@heavydutysys.com

# Merchandising Swing Glass Door Refrigerator



- **Exterior:** Coated steel. **Black or white finish available.**
- **Interior:** Attractive aluminum liner with stainless steel floor.
- **Refrigeration system** maintains temperatures between 33°F and 41°F(0.5°C to 5°C).
- **Self-Closing double pane glass door with positive seal.**
- **Shelves:** Adjustable heavy-duty PVC coated shelves.
- **Leveling feet or casters are available.**
- **LED lighting.**
- **Electronic control system** makes it easy to adjust temperature set point and defrost frequency.
- **Removable installation board** makes it easy to access condenser coil for cleaning and service.
- **These units use HYDRO-CARBON R290 refrigerant,** which is environmentally friendly and more efficient than R134a/R404a refrigerant.



**HDSMR-48-2**



**HDSMR-53-2**



**HDSMR-78-3**

MODEL	DOORS	SHELVES	DIMENSIONS - WxDxH		CAPACITY	HP	AMPS	VOLTAGE	PLUG TYPE
			inches	mm					
<b>HDSMR-48-2</b>	2	8	48 x 25 3/5 x 80 3/8	1220 x 650 x 2040	29 830	1/4+	4.8	115/60/1	NEMA 5-15P
<b>HDSMR-53-2</b>	2	8	53 1/8 x 31 7/8 x 79 3/8	1350 x 810 x 2015	45 1270	1/4+	4.3	115/60/1	NEMA 5-15P
<b>HDSMR-78-3</b>	3	12	78 3/8 x 30 x 80 3/4	1988 x 760 x 2050	53 1500	3/4	10.7	115/60/1	NEMA 5-20P

Specifications subject to change without notice.  
Voltage 220/50/1 available.  
Plug type varies by country.



HEAVY DUTY SYSTEMS  
Add : 143 West 29th Street, New York, NY 10001  
Tel : 212.924.6920 Fax : 212.627.1759 E-mail : sales@heavydutysys.com

# Merchandising Swing Glass Door Freezer



- **Exterior:** Coated steel. **Black or white finish available.**
- **Interior:** Attractive aluminum liner with stainless steel floor.
- **Refrigeration system** maintains temperatures between -10°F and 0°F (-23°C to -18°C).
- **Self-Closing double pane glass door** with positive seal.
- **Shelves:** Adjustable heavy-duty PVC coated shelves.
- **Leveling feet or casters are available.**
- **LED lighting.**
- **Electronic control system** makes it easy to adjust temperature set point and defrost frequency.
- **Removable installation board** makes it easy to access condenser coil for cleaning and service.
- **These units use HYDRO-CARBON R290 refrigerant,** which is environmentally friendly and more efficient than R134a/R404a refrigerant.



**HDSMF-26-1**



**HDSMF-27-1**



**HDSMF-31-1**

MODEL	DOORS	SHELVES	DIMENSIONS - WxDxH		CAPACITY	HP	AMPS	VOLTAGE	PLUG TYPE
			inches	mm					
<b>HDSMF-26-1</b>	1	2	26 4/5 x 26 x 55 7/8	680 x 660 x 1420	8.5 240	1/4+	3.5	115/60/1	NEMA 5-15P
<b>HDSMF-27-1</b>	1	4	27 1/5 x 26 1/5 x 80 3/8	690 x 665 x 2040	13 368	3/4	8.8	115/60/1	NEMA 5-15P
<b>HDSMF-31-1</b>	1	4	31 1/8 x 31 3/8 x 80 3/4	790 x 795 x 2050	23 648	3/4	9.4	115/60/1	NEMA 5-15P

Specifications subject to change without notice.  
Voltage 220/50/1 available.  
Plug type varies by country.



HEAVY DUTY SYSTEMS  
Add : 143 West 29th Street, New York, NY 10001  
Tel : 212.924.6920 Fax : 212.627.1759 E-mail : sales@heavydutysys.com

# Merchandising Swing Glass Door Freezer



- **Exterior:** Coated steel. **Black or white finish available.**
- **Interior:** Attractive aluminum liner with stainless steel floor.
- **Refrigeration system** maintains temperatures between -10°F and 0°F (-23°C to -18°C).
- **Self-Closing double pane glass door** with positive seal.
- **Shelves:** Adjustable heavy-duty PVC coated shelves.
- **Leveling feet or casters are available.**
- **LED lighting.**
- **Electronic control system** makes it easy to adjust temperature set point and defrost frequency.
- **Removable installation board** makes it easy to access condenser coil for cleaning and service.
- **These units use HYDRO-CARBON R290 refrigerant,** which is environmentally friendly and more efficient than R134a/R404a refrigerant.



**HDSMF-49-2**



**HDSMF-53-2**



**HDSMF-79-3**

MODEL	DOORS	SHELVES	DIMENSIONS - WxDxH		CAPACITY	HP	AMPS	VOLTAGE	PLUG TYPE
			inches	mm					
<b>HDSMF-49-2</b>	2	8	49 1/5 x 26 1/5 x 80 3/8	1250 x 665 x 2040	29 830	3/4	9.4	115/60/1	NEMA 5-15P
<b>HDSMF-53-2</b>	2	8	53 1/8 x 31 7/8 x 79 3/8	1350 x 810 x 2015	45 1270	1	9.2	115/60/1	NEMA 5-15P
<b>HDSMF-79-3</b>	3	12	79 1/2 x 30 3/5 x 80 3/4	2020 x 777 x 2050	52 1479	0.75 x 2	16.3	115/60/1	NEMA 5-20P

Specifications subject to change without notice.  
Voltage 220/50/1 available.  
Plug type varies by country.



HEAVY DUTY SYSTEMS  
Add : 143 West 29th Street, New York, NY 10001  
Tel : 212.924.6920 Fax : 212.627.1759 E-mail : sales@heavydutysys.com

# Cake Display Case



- **Refrigeration system** maintains temperatures between 36°F and 43°F( 2 °C to 6 °C).
- **Exterior:** Stainless steel floor and walls, standard.
- Sliding doors.
- 12V **LED lighting** system, safe for users to operate.
- **Tempered glass** to avoid injury by broken glass.
- Preinstalled hidden caster design.
- **NSF-7** compliant for open food product.
- **Shelves:** Adjustable glass shelves provide extra large viewing area to maximize bakery product presentation.
- **Electronic control system** makes it easy to adjust temperature set point and defrost frequency.
- **Removable installation board** makes it easy to access condenser coil for cleaning and service.
- **Option of HYDRO-CARBON R290 refrigerant available.**



**HDSRCD35-2**



**HDSRCD47-2**



**HDSRCD59-2**



**HDSRCD70-2**

MODEL	DOORS	SHELVES	DIMENSIONS - WxDxH		CAPACITY	HP	AMPS	VOLTAGE	PLUG TYPE
			inches	mm					
<b>HDSRCD35-2</b>	2	2	35 3/8 × 28 3/4 × 47 1/4	900 × 730 × 1200	11.3 320	1/3+	6.9	115/60/1	NEMA 5-15P
<b>HDSRCD47-2</b>	2	2	47 1/4 × 28 3/4 × 47 1/4	1200 × 730 × 1200	14 400	1/3+	7.2	115/60/1	NEMA 5-15P
<b>HDSRCD59-2</b>	2	2	59 1/8 × 28 3/4 × 47 1/4	1500 × 730 × 1200	17.7 500	1/2+	8.1	115/60/1	NEMA 5-15P
<b>HDSRCD70-2</b>	2	2	70 7/8 × 28 3/4 × 47 1/4	1800 × 730 × 1200	21.2 600	1/2+	8.3	115/60/1	NEMA 5-15P

Specifications subject to change without notice.  
Voltage 220/50/1 available.  
Plug type varies by country.



HEAVY DUTY SYSTEMS  
Add : 143 West 29th Street, New York, NY 10001  
Tel : 212.924.6920 Fax : 212.627.1759 E-mail : sales@heavydutysys.com



# Cake Display Case



- **Refrigeration system** maintains temperatures between 36°F and 43°F ( 2°C to 6°C).
- **Exterior:** Stainless steel floor and walls, standard.
- **Sliding doors.**
- 12V **LED lighting** system, safe for users to operate.
- **Tempered glass** to avoid injury by broken glass. Preinstalled hidden caster design.
- **NSF-7** compliant for open food product.

- **Shelves:** Adjustable glass shelves provide extra large viewing area to maximize bakery product presentation.
- **Electronic control system** makes it easy to adjust temperature set point and defrost frequency.
- **Removable installation board** makes it easy to access condenser coil for cleaning and service.
- **Option of HYDRO-CARBON R290 refrigerant available.**



**HDSRCD35-3**



**HDSRCD47-3**



**HDSRCD59-3**



**HDSRCD70-3**

MODEL	DOORS	SHELVES	DIMENSIONS - WxDxH		CAPACITY cu.ft. liters	HP	AMPS	VOLTAGE	PLUG TYPE
			inches	mm					
<b>HDSRCD35-3</b>	2	3	35 3/8 × 28 3/4 × 55 1/8 900 × 730 × 1400		12.7 360	1/3+	7.3	115/60/1	NEMA 5-15P
<b>HDSRCD47-3</b>	2	3	47 1/4 × 28 3/4 × 55 1/8 1200 × 730 × 1400		19.4 550	1/3+	7.3	115/60/1	NEMA 5-15P
<b>HDSRCD59-3</b>	2	3	59 1/8 × 28 3/4 × 55 1/8 1500 × 730 × 1400		25 700	1/2+	8.3	115/60/1	NEMA 5-15P
<b>HDSRCD70-3</b>	2	3	70 7/8 × 28 3/4 × 55 1/8 1800 × 730 × 1400		30 850	1/2+	8.5	115/60/1	NEMA 5-15P

Specifications subject to change without notice.  
Voltage 220/50/1 available.  
Plug type varies by country.



HEAVY DUTY SYSTEMS  
Add : 143 West 29th Street, New York, NY 10001  
Tel : 212.924.6920 Fax : 212.627.1759 E-mail : sales@heavydutysys.com

- **Cabinet finish:** White-coated steel exterior with stainless steel lid and door with lock and latch. Interior is NSF approved white aluminum liner with stainless steel floor.
- **Option of all stainless steel exterior available.**
- **Heavy duty construction:** CFC and HCFC-free foamed-in-place polyurethane insulation.
- **Refrigeration system:** Single access, cold wall milk coolers maintain milk temperature of 33°F- 38°F (0.5°C- 3.3°C).
- **Preinstalled heavy-duty casters with brakes.**
- **Electronic control system** makes it easy to adjust temperature set point.
- **Bottom floor drain** is centrally located for easy cleaning, connecting to drain hose with hose adapter.
- **Removable installation board** makes it easy to access condenser coil for cleaning and service.
- **These units use HYDRO-CARBON R290 refrigerant,** which is environmentally friendly and more efficient than R134a/R404a refrigerant.



**HDSMC-34**



**HDSMC-49**



**HDSMC-58**

MODEL	DOORS	DIMENSIONS - WxDxH		CAPACITY		HP	AMPS	VOLTAGE	PLUG TYPE
		inches	mm	13"x13"x11" cases	19"x13"x11" cases				
<b>HDSMC-34</b>	2	34 × 30 3/5 × 40 864 × 778 × 1052		8	4	1/5	2.28	115/60/1	NEMA 5-15P
<b>HDSMC-49</b>	2	49 × 30 3/5 × 40 1245 × 778 × 1052		12	8	1/5	2.28	115/60/1	NEMA 5-15P
<b>HDSMC-58</b>	2	58 × 30 3/5 × 40 1475 × 778 × 1052		16	10	1/5	2.4	115/60/1	NEMA 5-15P

Specifications subject to change without notice.  
Voltage 220/50/1 available.  
Plug type varies by country.



HEAVY DUTY SYSTEMS  
Add : 143 West 29th Street, New York, NY 10001  
Tel : 212.924.6920 Fax : 212.627.1759 E-mail : sales@heavydutysys.com

# Outdoor Rated Small Refrigerator



- **Stainless steel interior and exterior.**  
Option of bright white aluminum interior available.
- **Refrigeration system** keeps food at safe temperatures between 33°F and 41°F(0.5°C to 5°C).
- Stainless steel heavy-duty door with enduring quality. Locks and keys included.
- Simple installation with no plumbing required.
- **Electronic control system** makes it easy to adjust temperature set point and defrost frequency.
- **Preinstalled heavy-duty casters.**
- GN1/1 pan is suitable.
- Shelves: Adjustable heavy-duty PVC coated shelves.



**HDSOR-23**

MODEL	DOORS	SHELVES	DIMENSIONS - WxDxH		CAPACITY	HP	AMPS	VOLTAGE	PLUG TYPE
			inches	mm					
<b>HDSOR-23</b>	1	2	23 2/5 x 24 3/4 x 32 3/4	595 x 628 x 830	5.7 161	1/6	2.2	115/60/1	NEMA 5-15P

Specifications subject to change without notice.  
Voltage 220/50/1 available.  
Plug type varies by country.



HEAVY DUTY SYSTEMS  
Add : 143 West 29th Street, New York, NY 10001  
Tel : 212.924.6920 Fax : 212.627.1759 E-mail : sales@heavydutysys.com

# Countertop Merchandiser



- **Exterior:** Coated steel. **Black or white or S/S finish available.**  
**Interior :** Attractive aluminum liner with stainless steel floor.
- **Refrigeration system:** maintains temperatures between 33°F and 41°F (0.5°C to 5°C).
- Swing glass door.
- **Shelves:** Adjustable heavy-duty PVC coated shelves.
- **LED lighting.**
- **Electronic control system** makes it easy to adjust temperature set point and defrost frequency.
- **R290 natural refrigerant.**
- **Removable installation board** makes it easy to access condenser coil for cleaning and service.



**HDSRCM-24**



**HDSRCM-24H**

MODEL	DOORS	SHELVES	DIMENSIONS - WxDxH		CAPACITY		HP	AMPS	VOLTAGE	PLUG TYPE
			inches	mm	cu.ft.	liters				
<b>HDSRCM-24</b>	1	2	24 2/5 x 25 1/5 x 33 1/4	620 x 640 x 845	5	140	1/5	1.8	115/60/1	NEMA 5-15P
<b>HDSRCM-24H</b>	1	3	24 2/5 x 25 1/5 x 38 3/5	620 x 640 x 980	6.4	180	1/5	2	115/60/1	NEMA 5-15P

Specifications subject to change without notice.  
Voltage 220/50/1 available.  
Plug type varies by country.



HEAVY DUTY SYSTEMS  
Add : 143 West 29th Street, New York, NY 10001  
Tel : 212.924.6920 Fax : 212.627.1759 E-mail : sales@heavydutysys.com

# Dipping Cabinet



- Stainless steel top with glass viewing window.  
Bright white painted steel interior and exterior.
- Refrigeration system keeps ice cream at temperatures between -10°F and 5°F (-23°C to -15°C).
- Transparent lids hinged with a full length handle.
- Plastic can holder for each container rack.
- LED lighting.
- **Electronic control system** makes it easy to adjust temperature set point and defrost frequency.
- Removable installation board makes it easy to access condenser coil for cleaning and service.
- These units use HYDRO-CARBON R290 refrigerant, which is environmentally friendly and more efficient than R134a/R404a refrigerant.



**HSDSDPC-47**



**HSDSDPC-68**

MODEL	LIDS	RACKS	DIMENSIONS - WxDxH		CAPACITY	HP	AMPS	VOLTAGE	PLUG TYPE
			inches	mm					
<b>HSDSDPC-47</b>	1	8	47 x 27 3/4 x 51 1/8	1195 x 705 x 1300	8	1/4+	5.16	115/60/1	NEMA 5-15P
			4						
<b>HSDSDPC-68</b>	2	12	67 3/4 x 27 3/4 x 51 1/8	1720 x 705 x 1300	12	1/2+	5.64	115/60/1	NEMA 5-15P
			8						

Specifications subject to change without notice.  
Voltage 220/50/1 available.  
Plug type varies by country.



HEAVY DUTY SYSTEMS  
Add : 143 West 29th Street, New York, NY 10001  
Tel : 212.924.6920 Fax : 212.627.1759 E-mail : sales@heavydutysys.com

# Refrigerated Bakery Case with Curved Glass



- **Exterior: Stainless steel exterior with 4-sided, double-glass**  
Front: Attractive curved glass
- Refrigeration system maintains temperatures between 36°F and 43°F (2°C to 6°C).
- Sliding glass door.
- **Shelves:** Adjustable heavy-duty PVC coated shelves.
- **LED lighting.**
- **Electronic control system** makes it easy to adjust temperature set point and defrost frequency.
- **R290 natural refrigerant.**
- **Removable installation board** makes it easy to access condenser coil for cleaning and service.



**HDSRBC-50**



**HDSRBC-59**

MODEL	DOORS	SHELVES	DIMENSIONS - WxDxH		CAPACITY	HP	AMPS	VOLTAGE	PLUG TYPE
			inches	mm					
<b>HDSRBC-50</b>	2	6	50 x 34 x 49 1/5	1270 x 865 x 1250	22.6 640	3/4	7.7	115/60/1	NEMA 5-15P
<b>HDSRBC-59</b>	2	6	59 x 34 x 49 1/5	1500 x 865 x 1250	27.2 770	3/4	8	115/60/1	NEMA 5-15P

Specifications subject to change without notice.  
Voltage 220/50/1 available.  
Plug type varies by country.



HEAVY DUTY SYSTEMS  
Add : 143 West 29th Street, New York, NY 10001  
Tel : 212.924.6920 Fax : 212.627.1759 E-mail : sales@heavydutysys.com

# Plan View

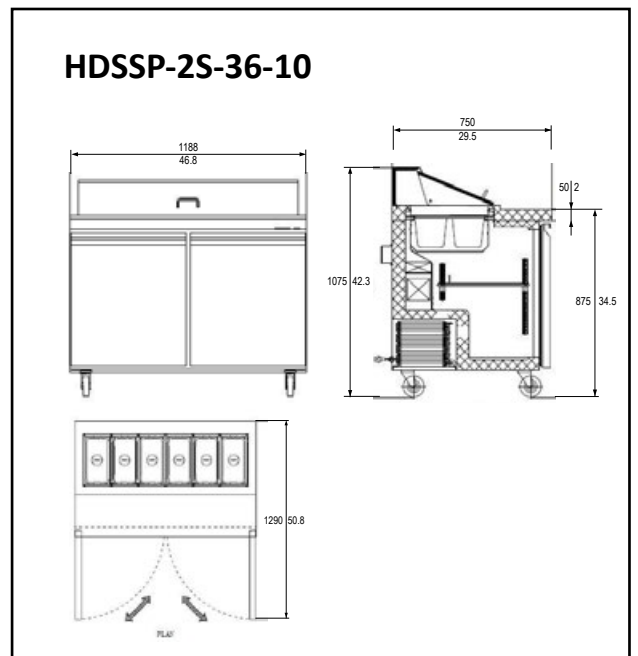
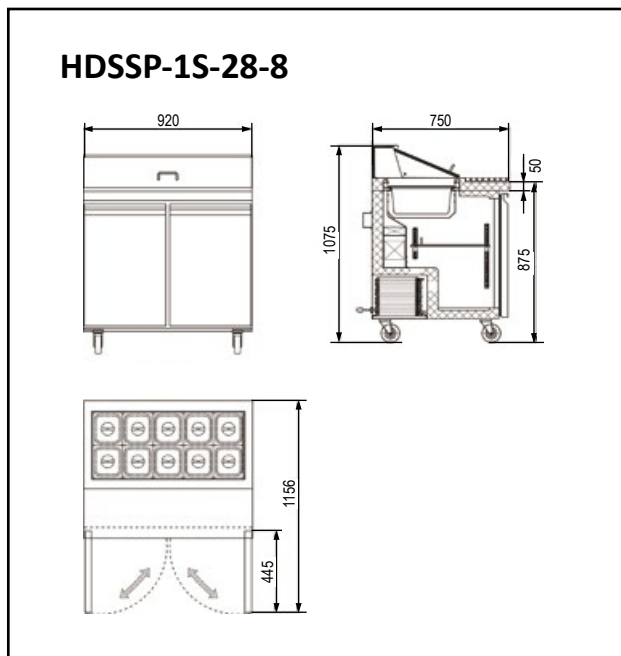
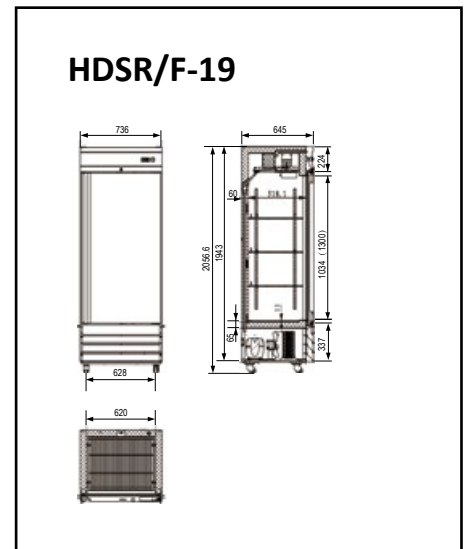
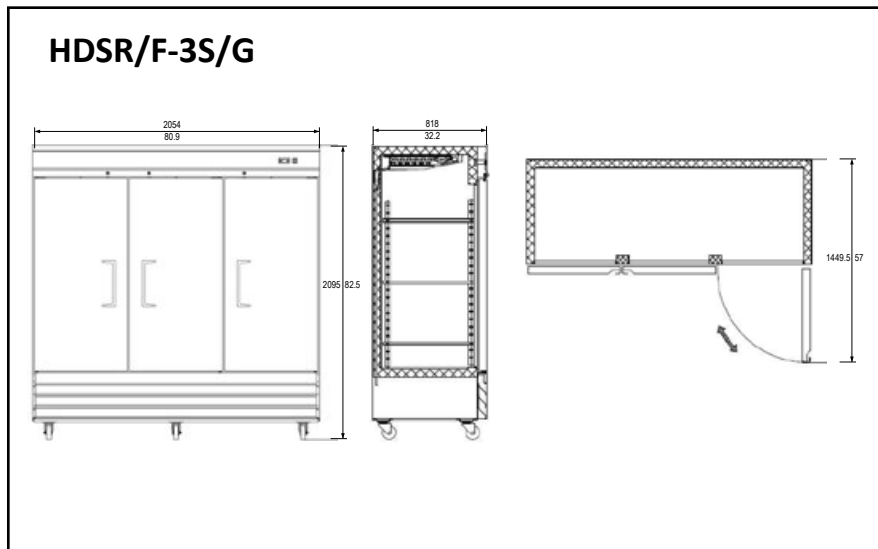
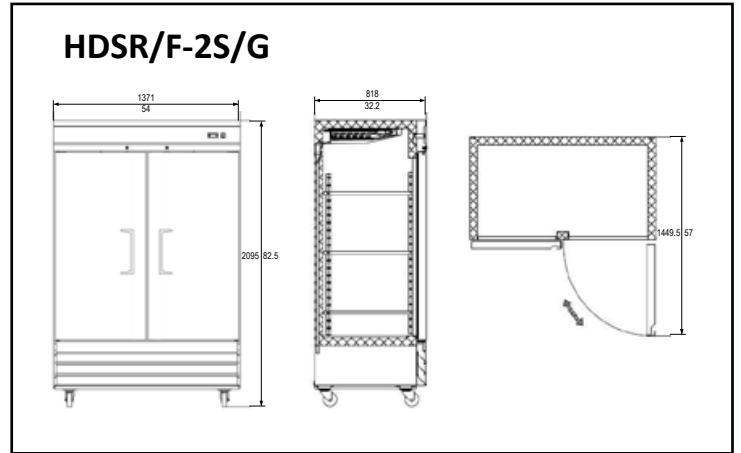
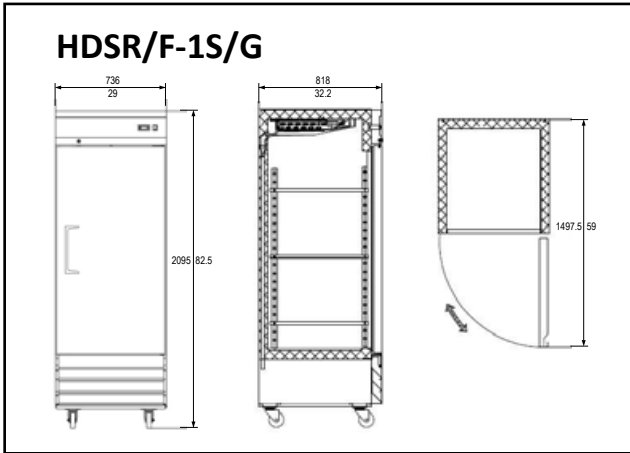

# Plan View

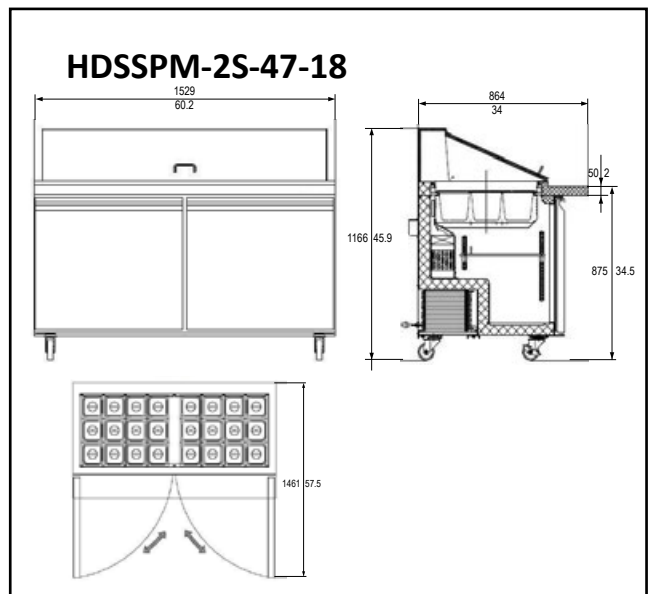
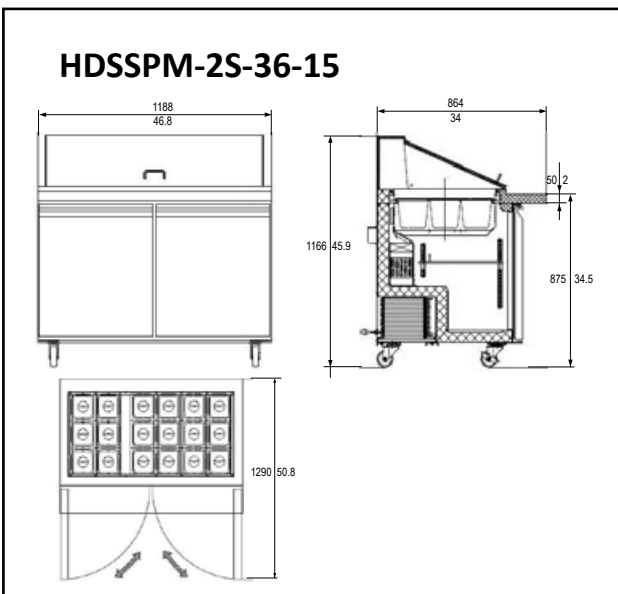
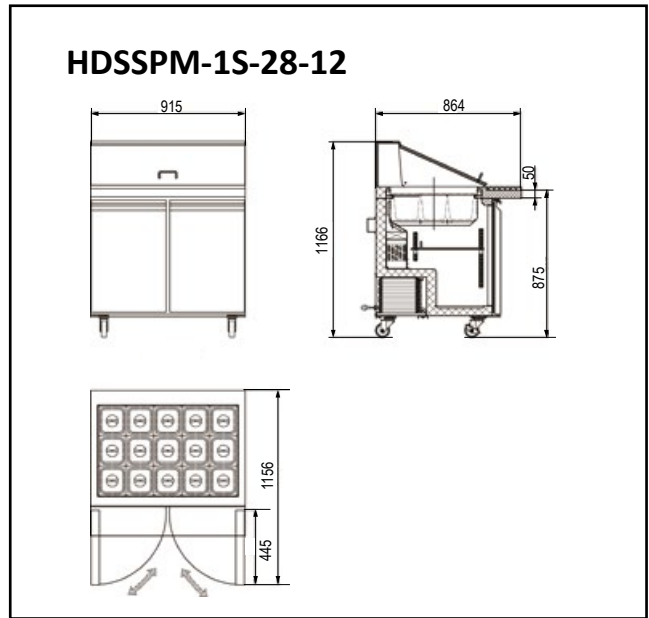
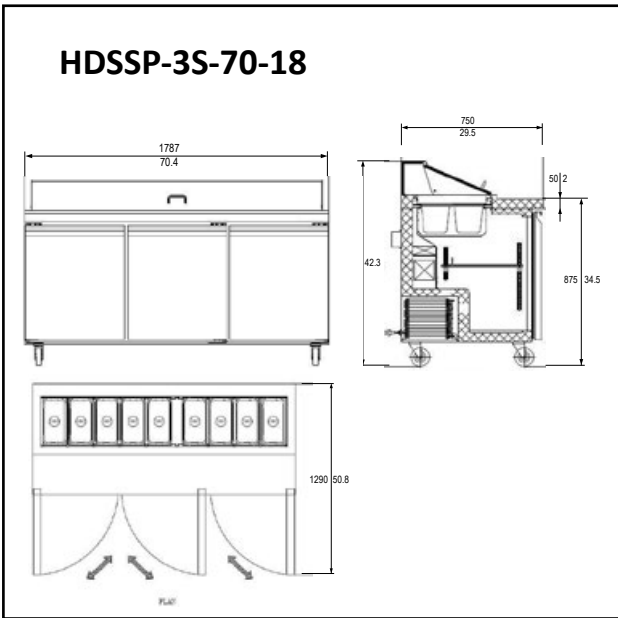
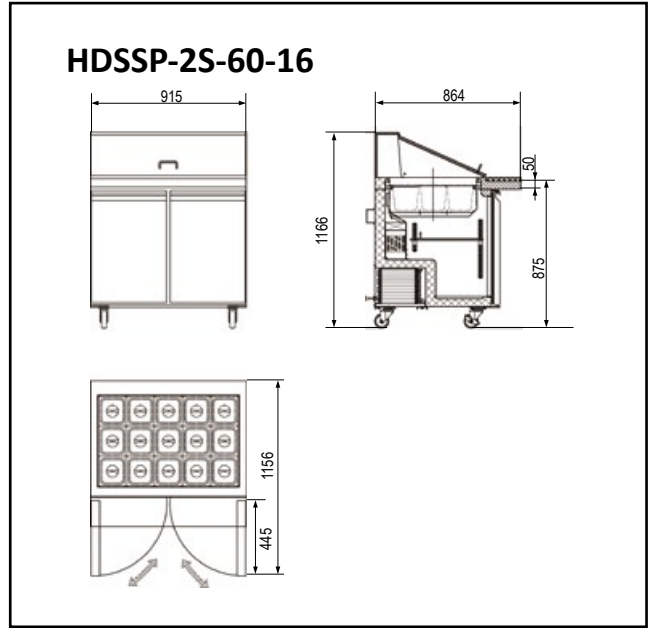
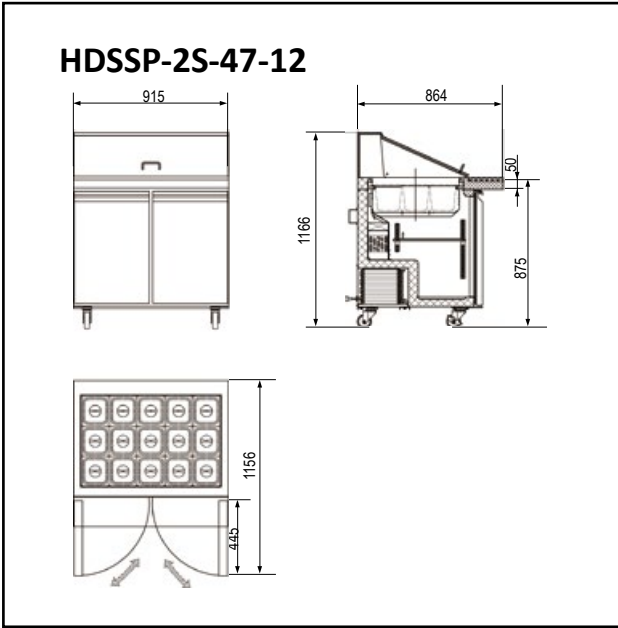



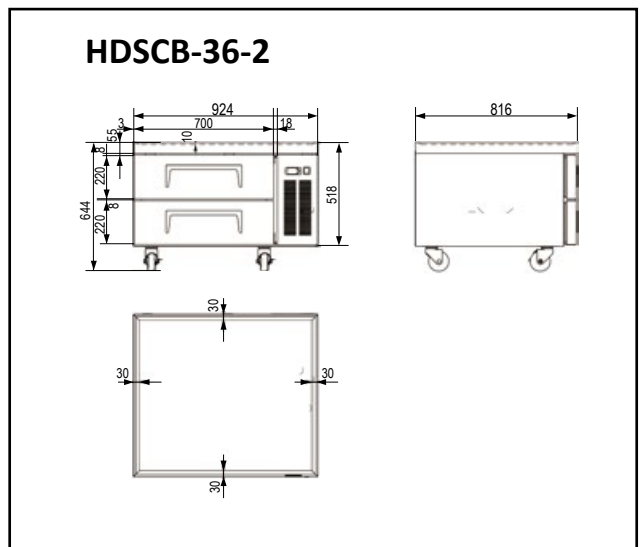
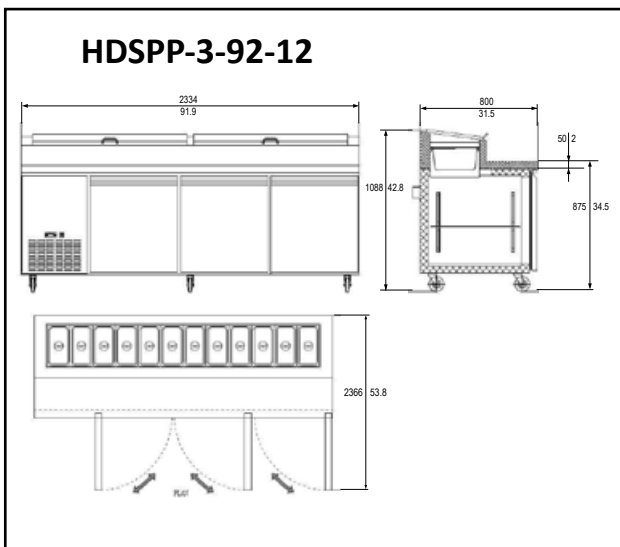
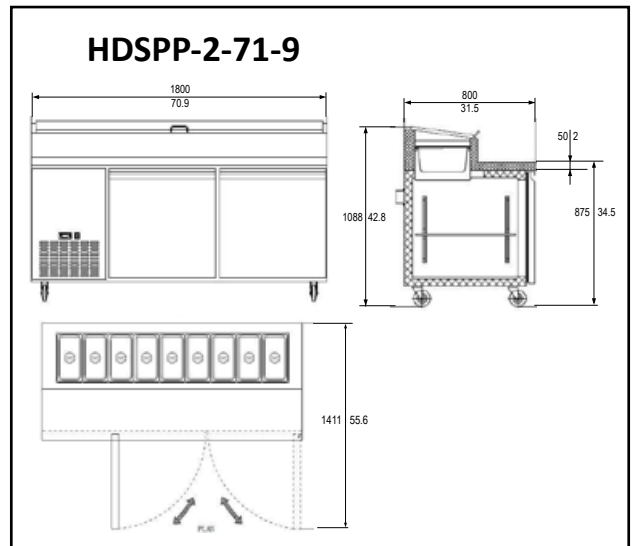
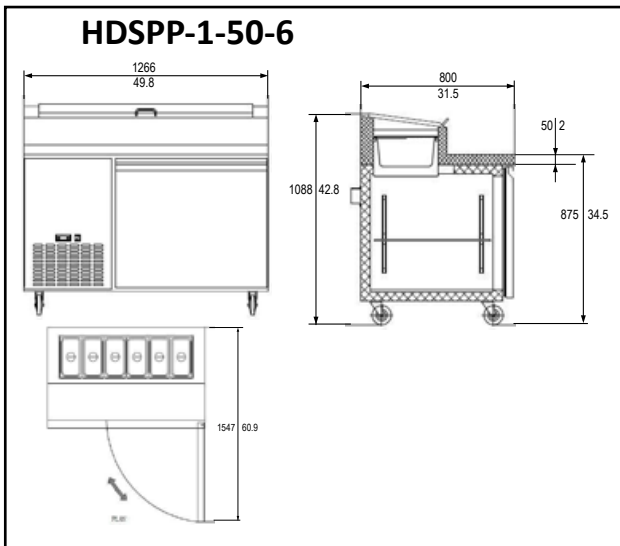
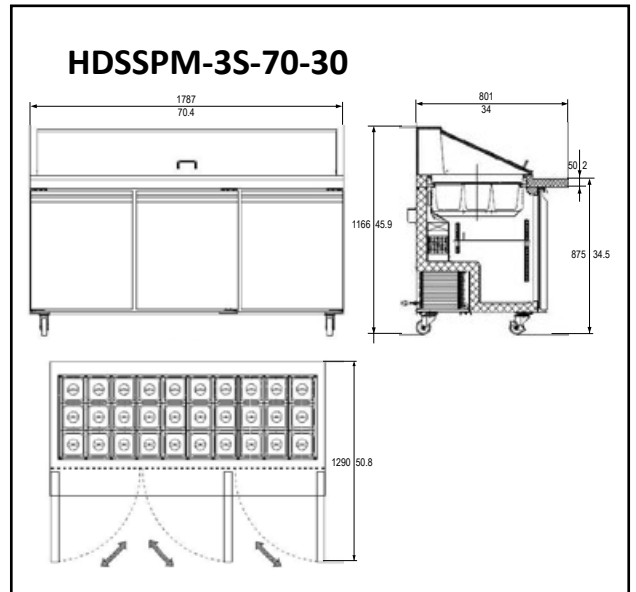
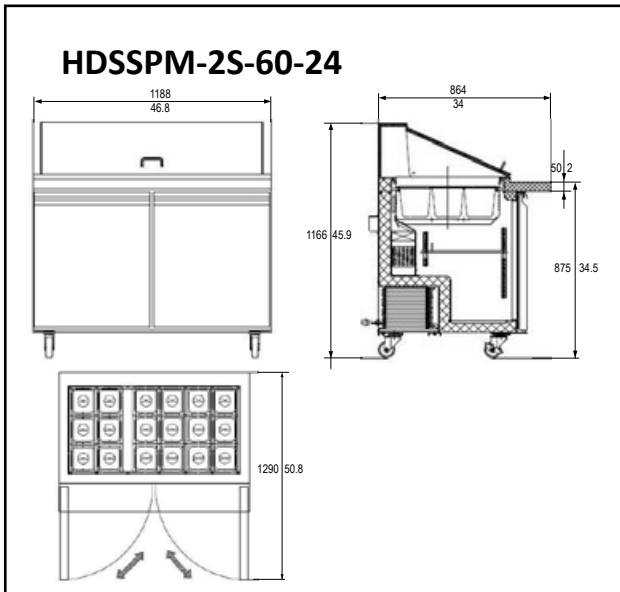

# Plan View

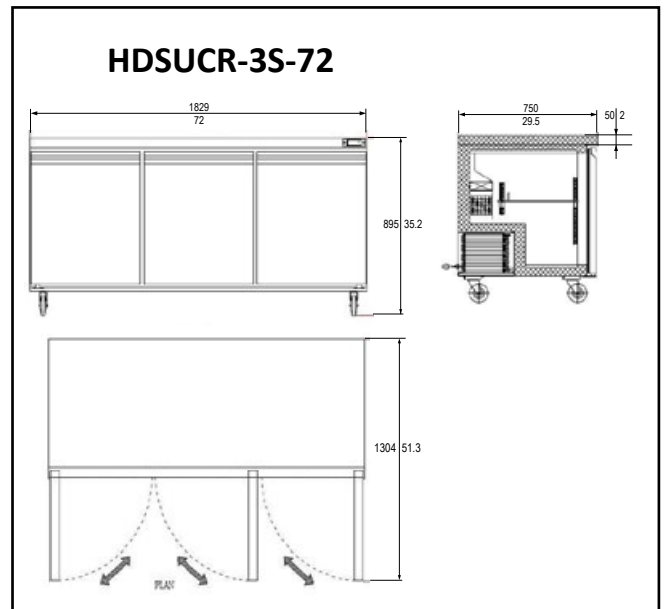
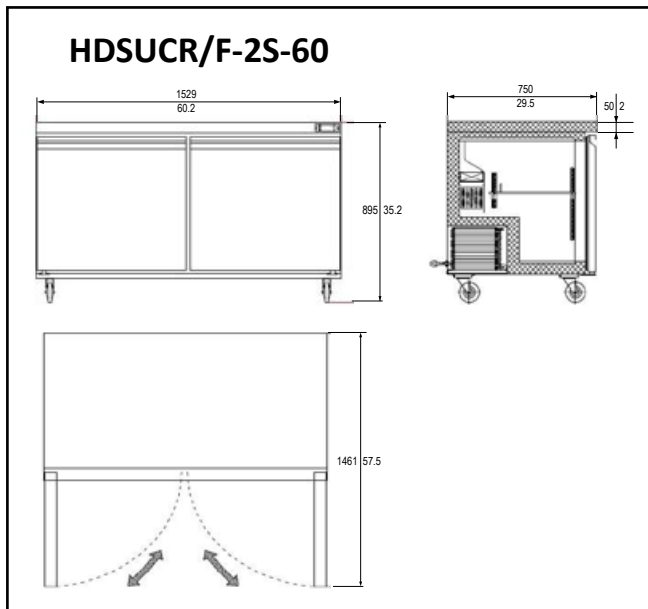
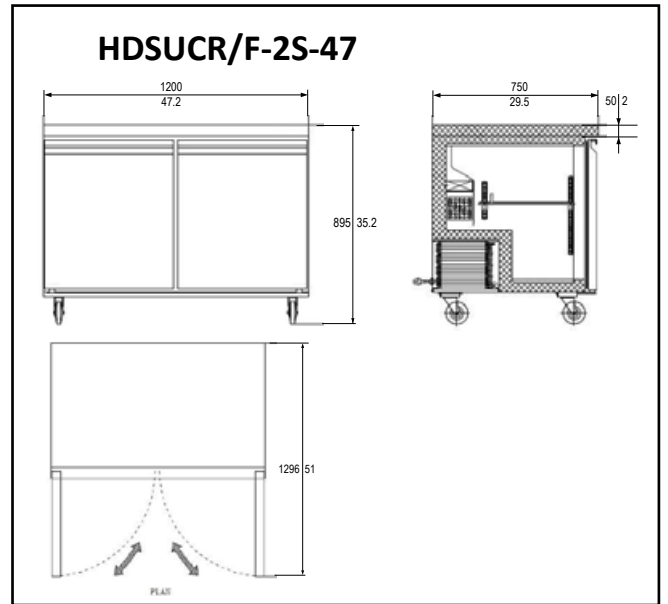
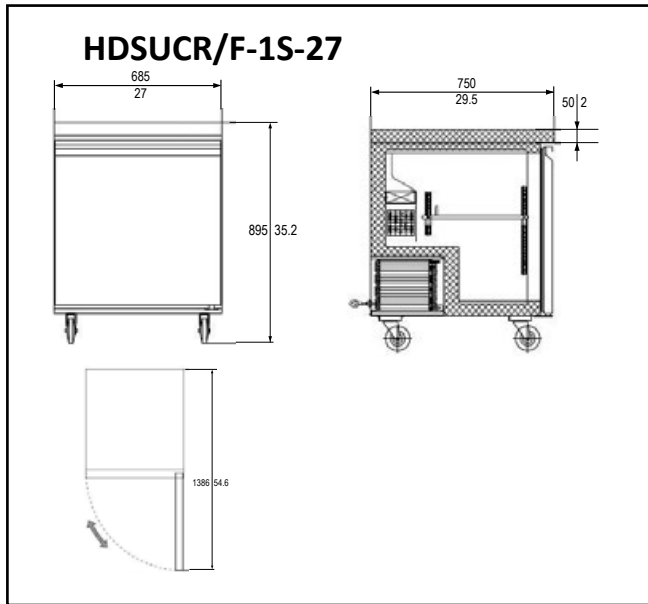
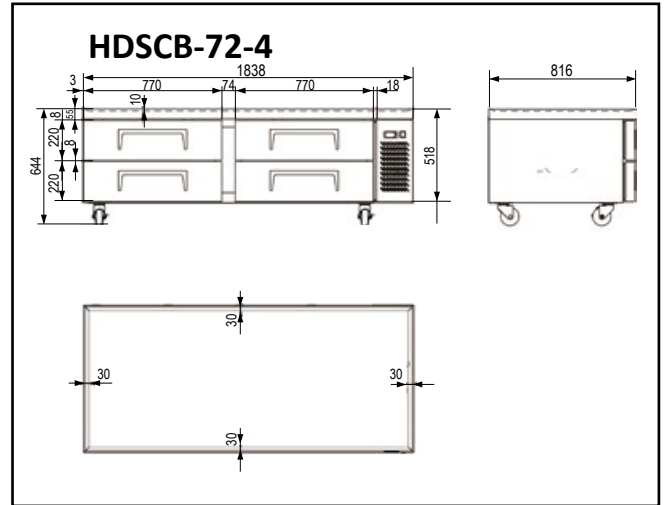
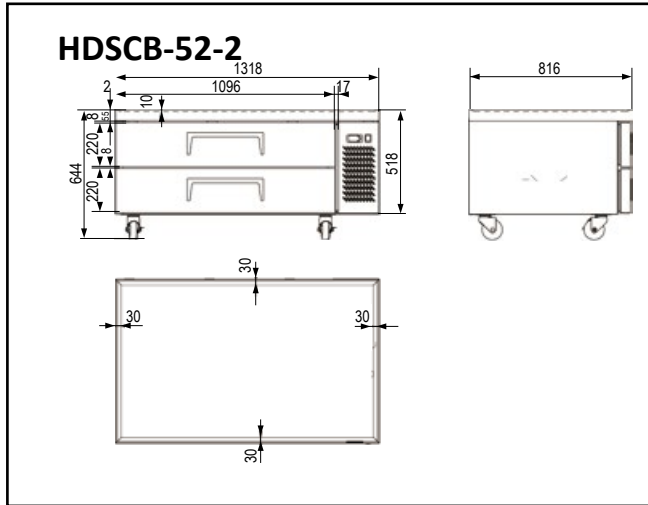

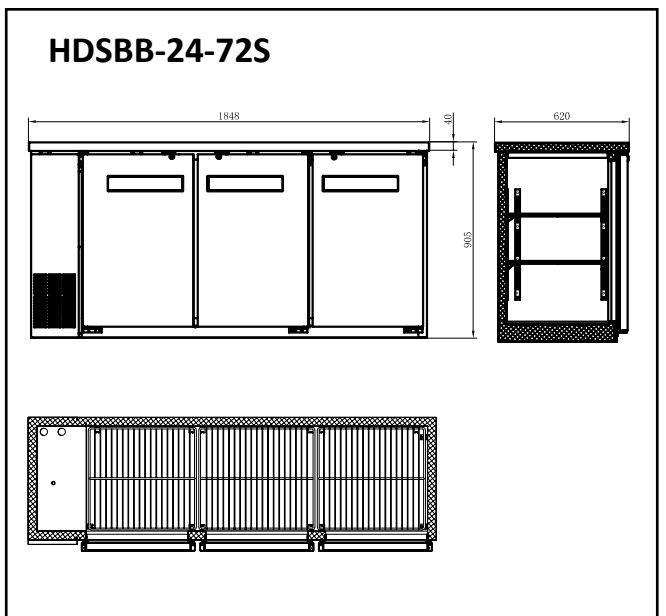
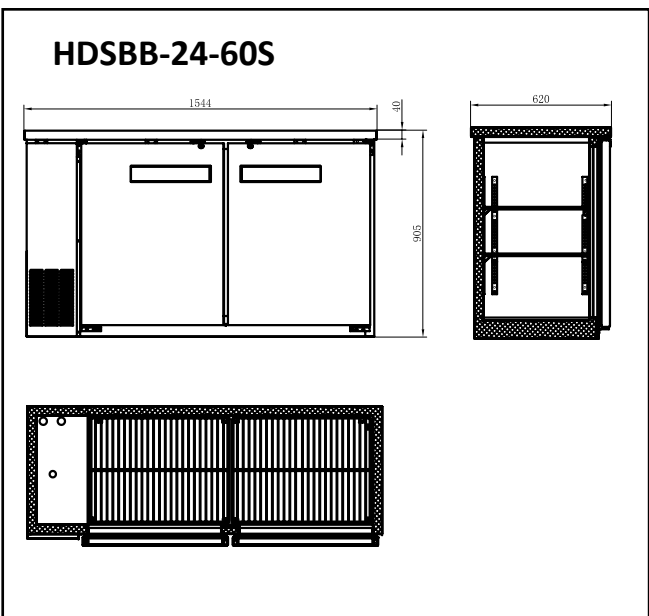
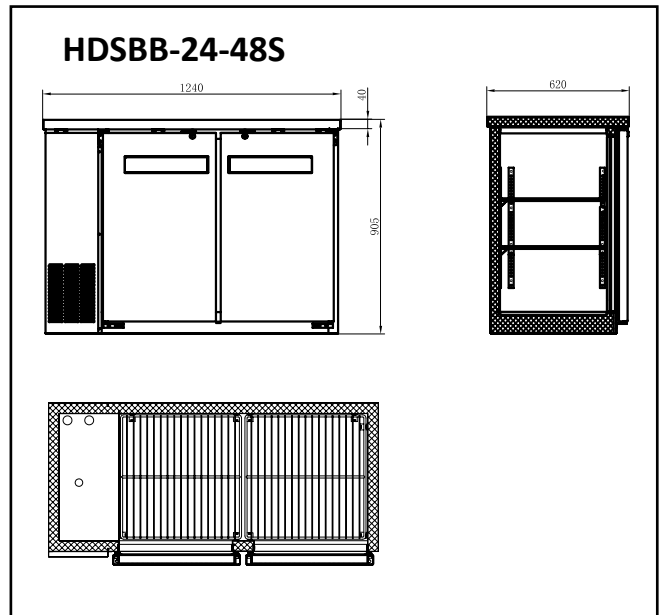
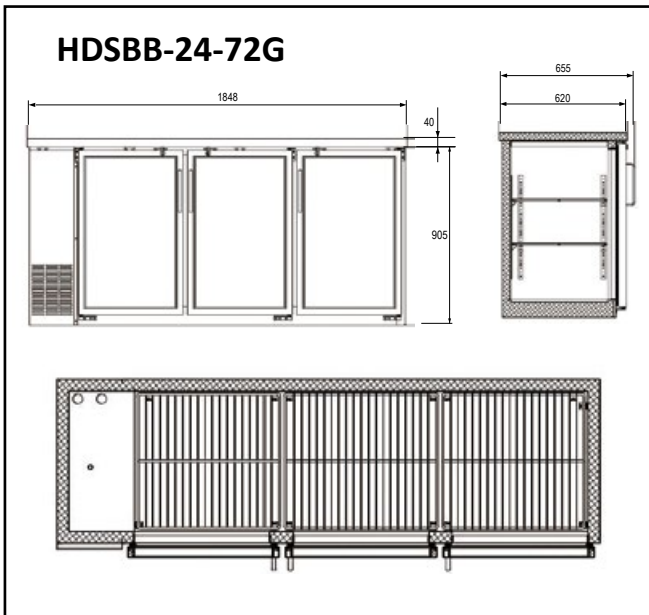
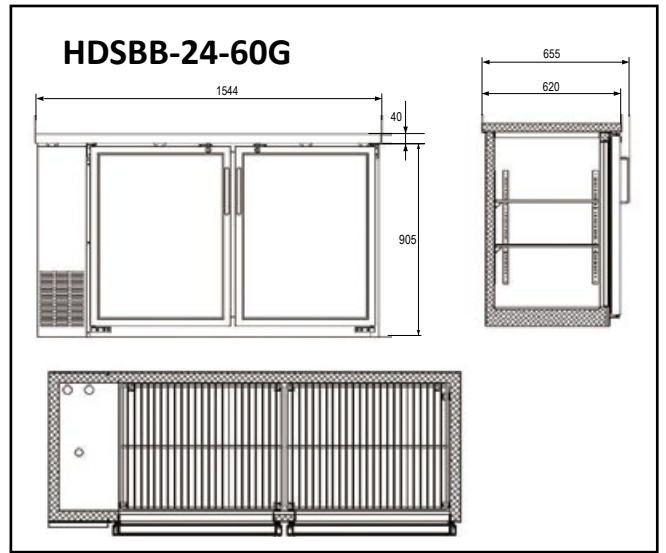
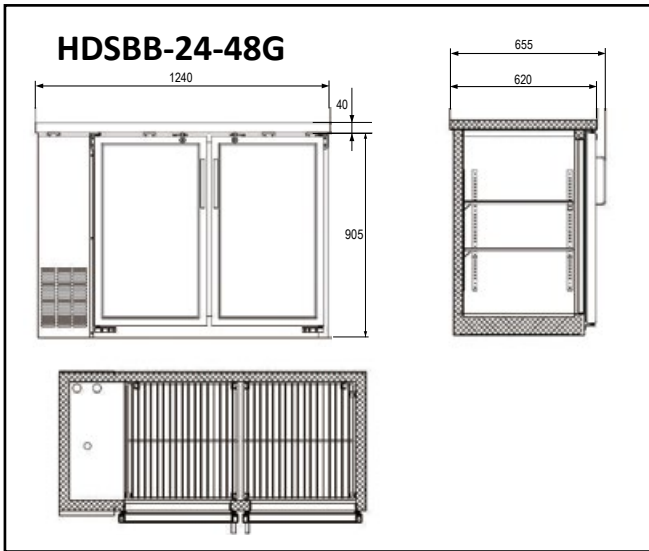

# Plan View

## HDSDD-24-48

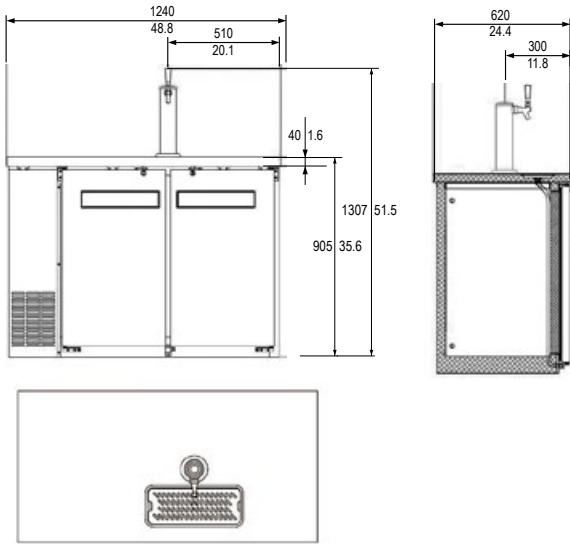

## HDSDD-24-60

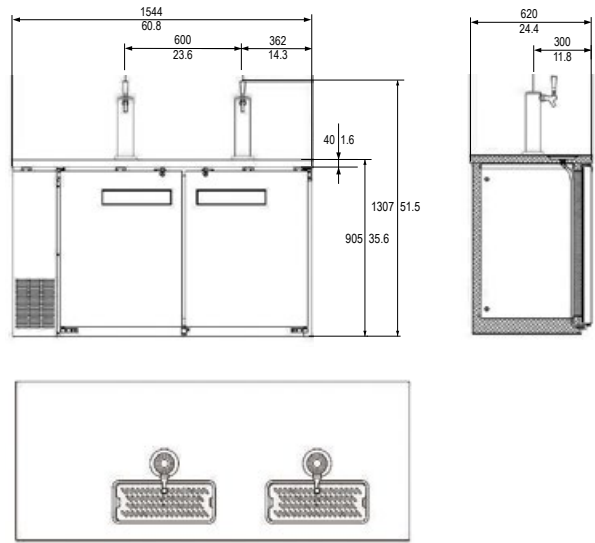

## HDSDD-24-72

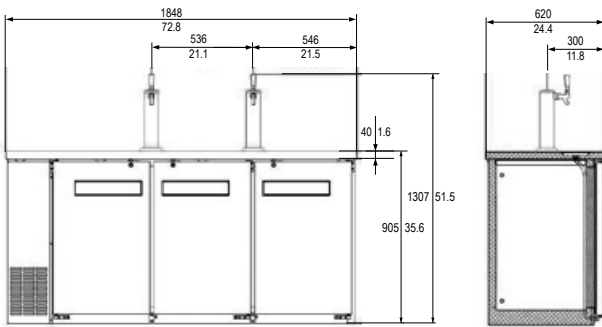

## HDSDD-30-23

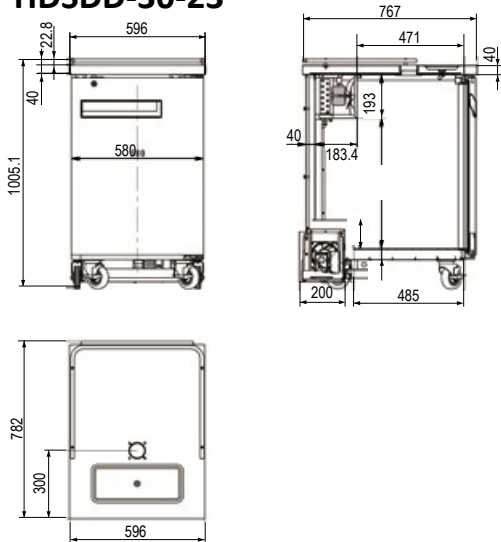

## HDSDD-27-58

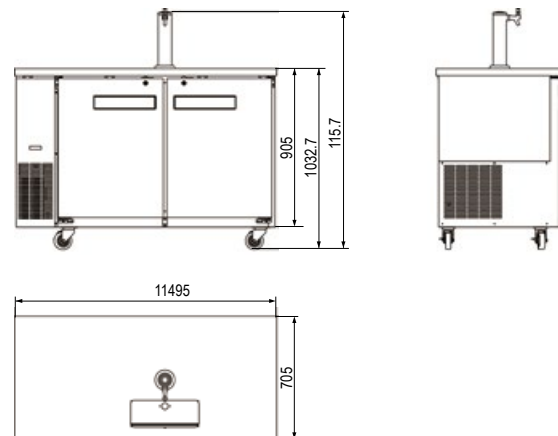

### HDSDD-27-69

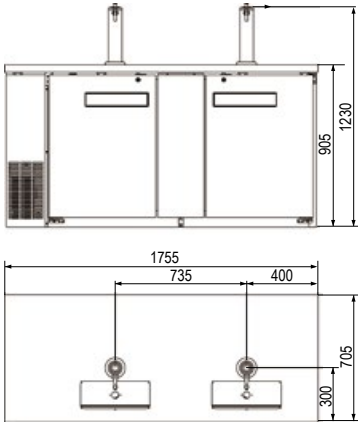

### HDSDD-27-90

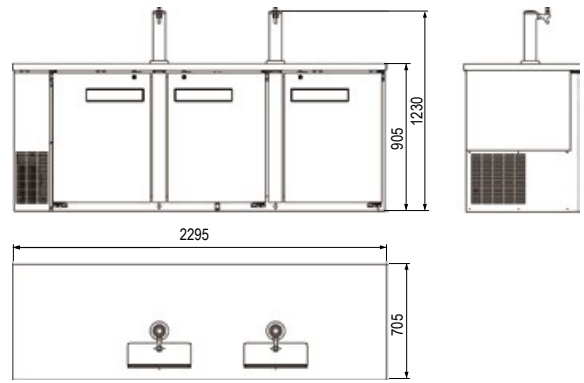

### HDSBC-26

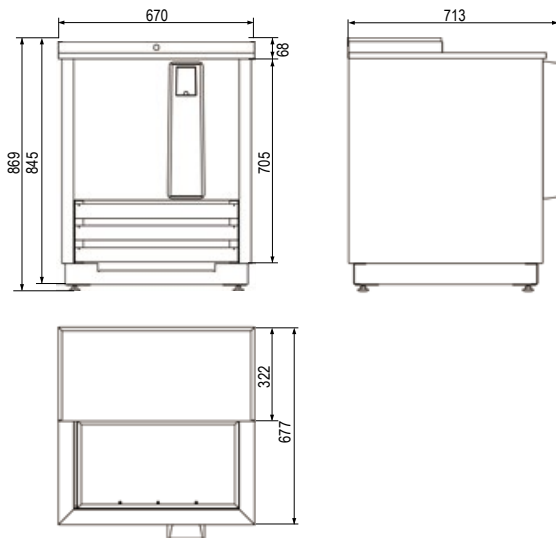

### HDSBC-49

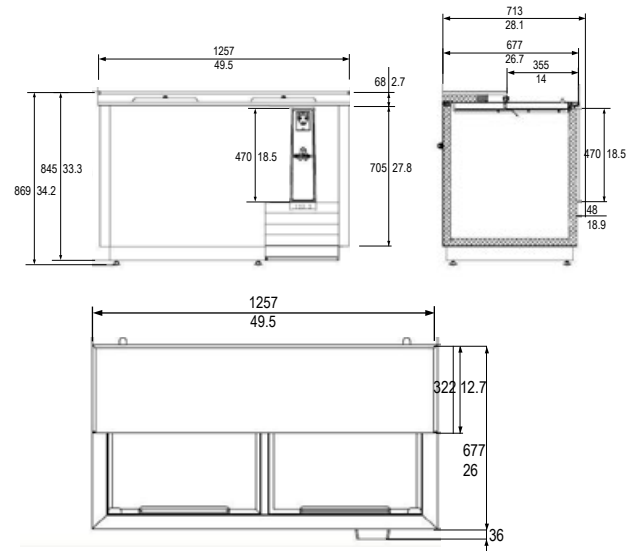

### HDSBC-64

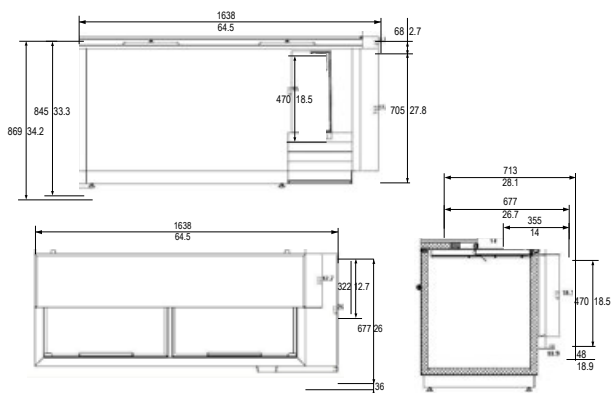

### HDSBC-95

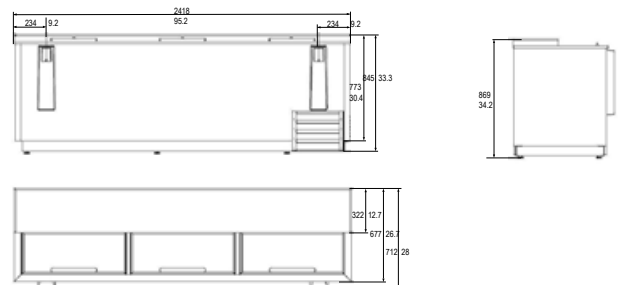

# Plan View

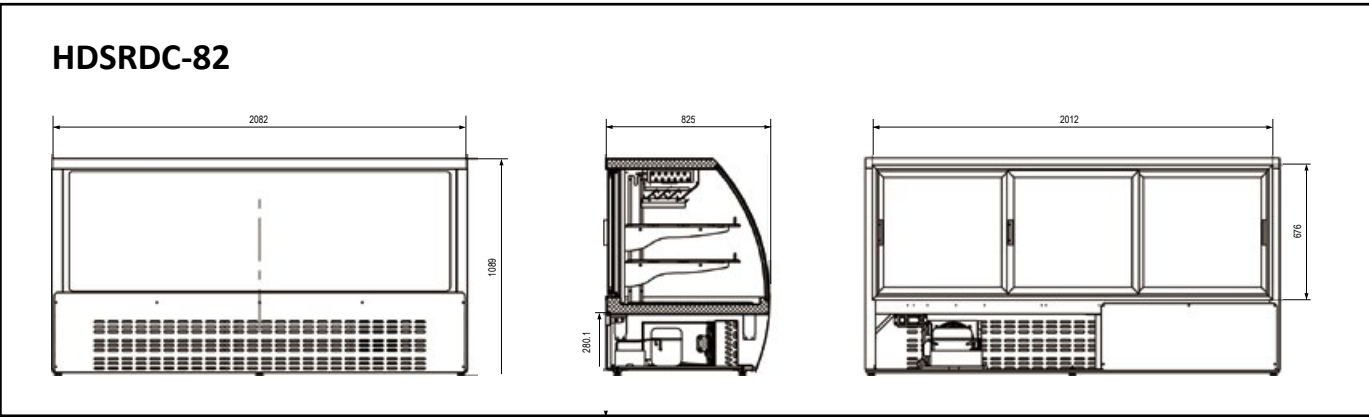
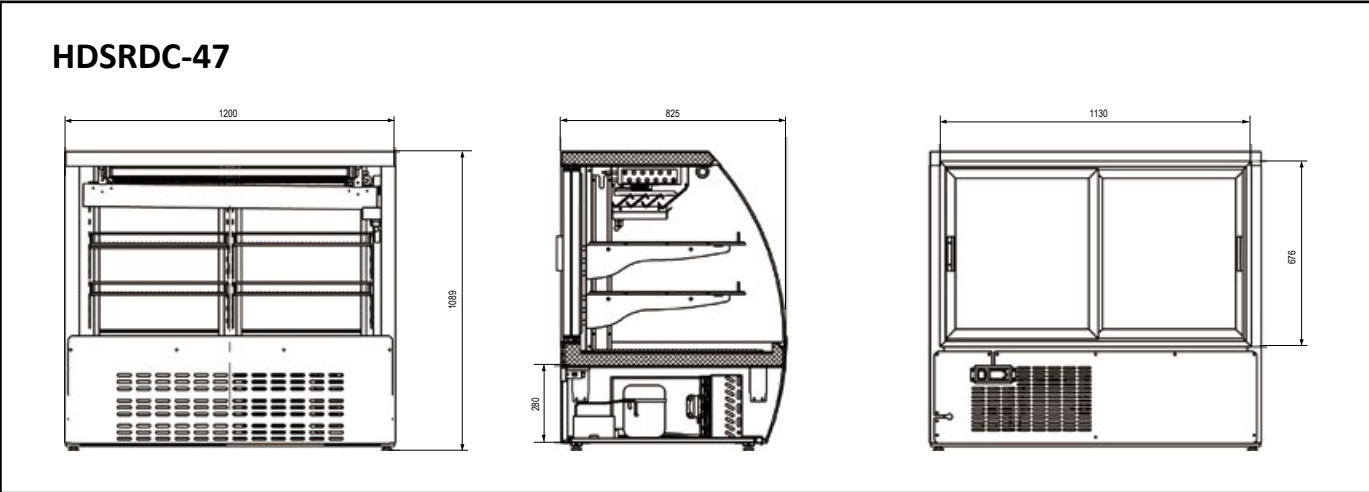
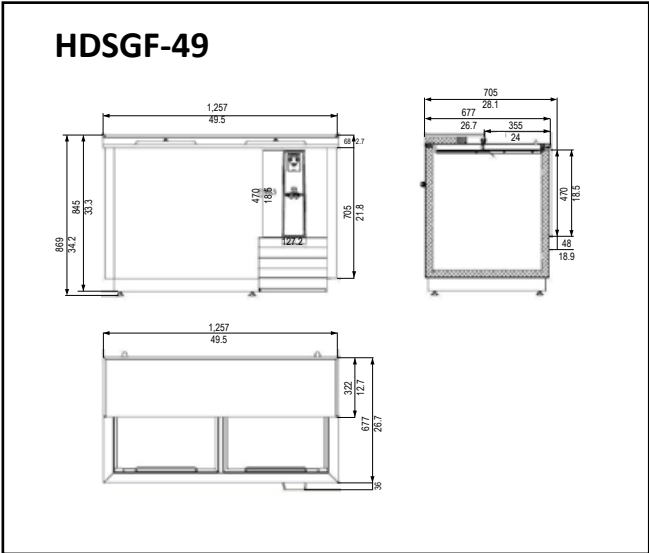
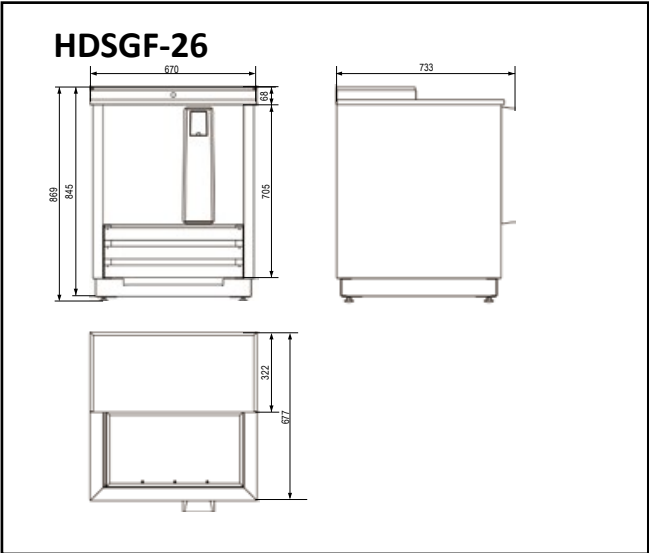

### HDSMR-21-1

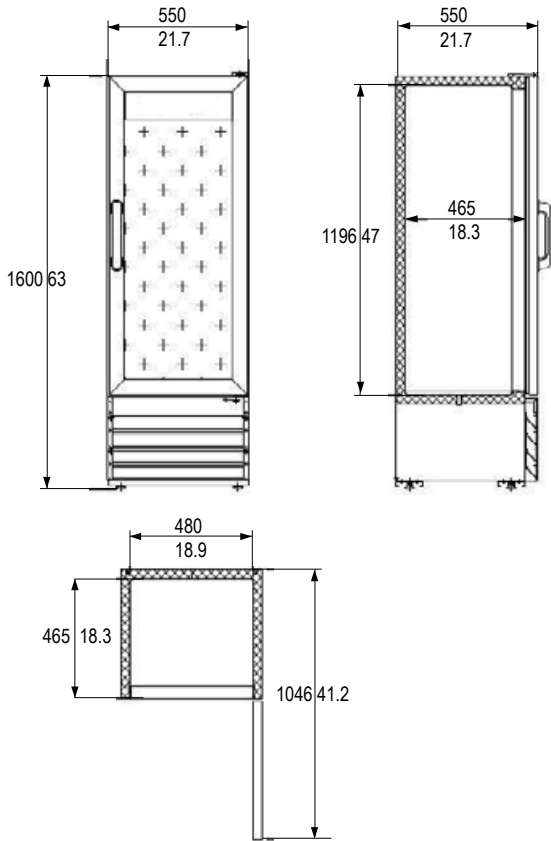

### HDSMR-25-1

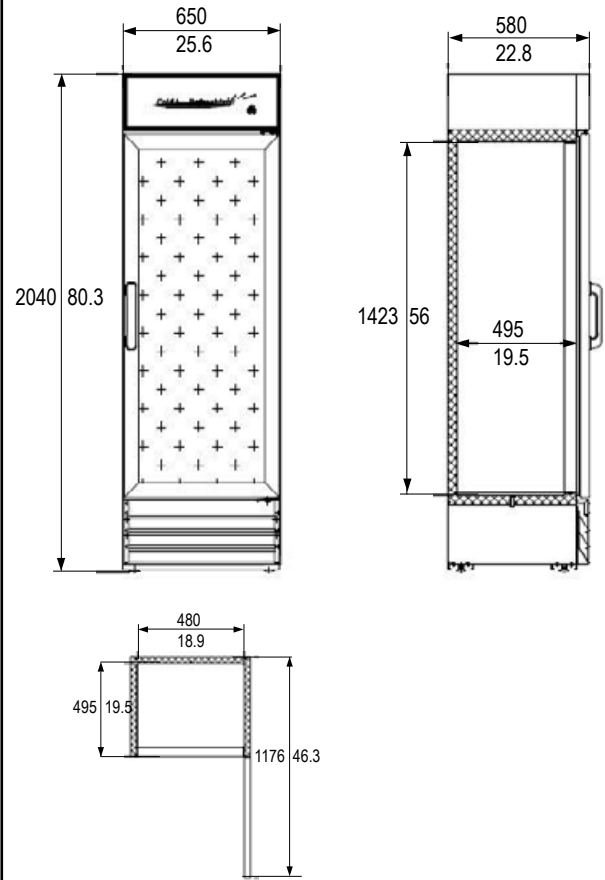

### HDSMR-28-1

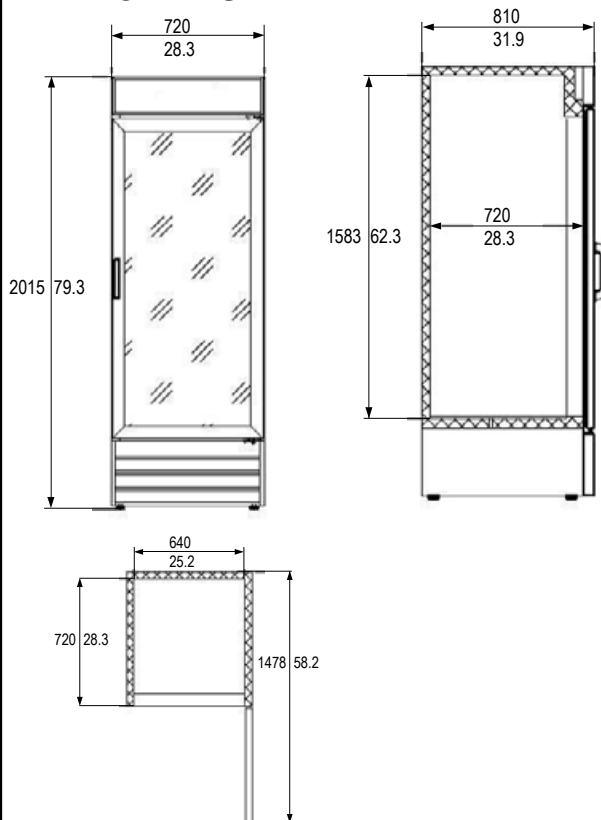

### HDSMR-53-2-Y

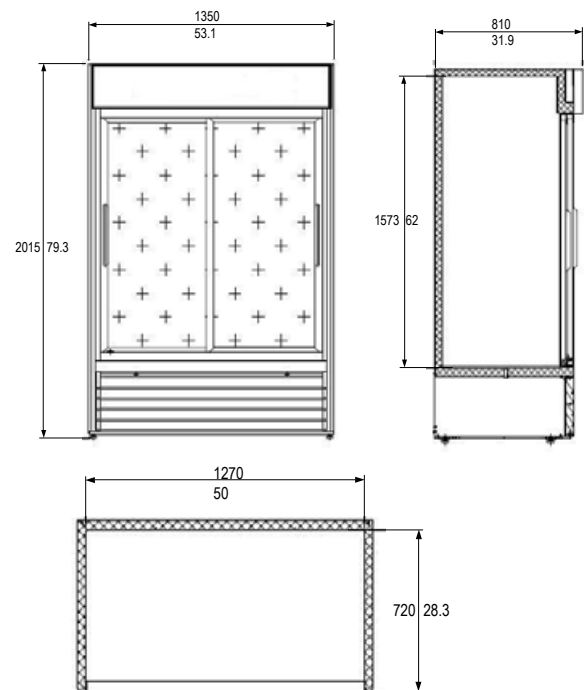

# Plan View

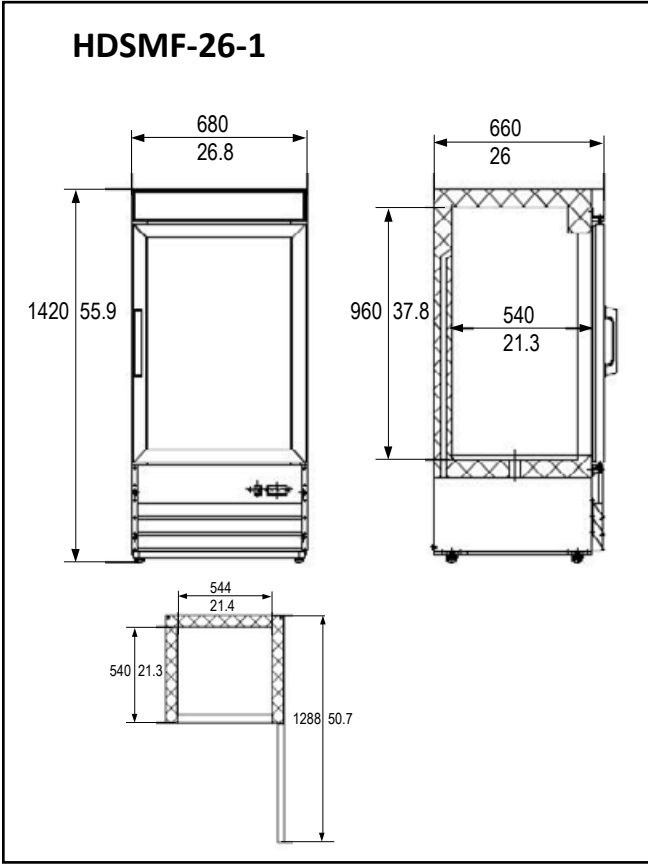
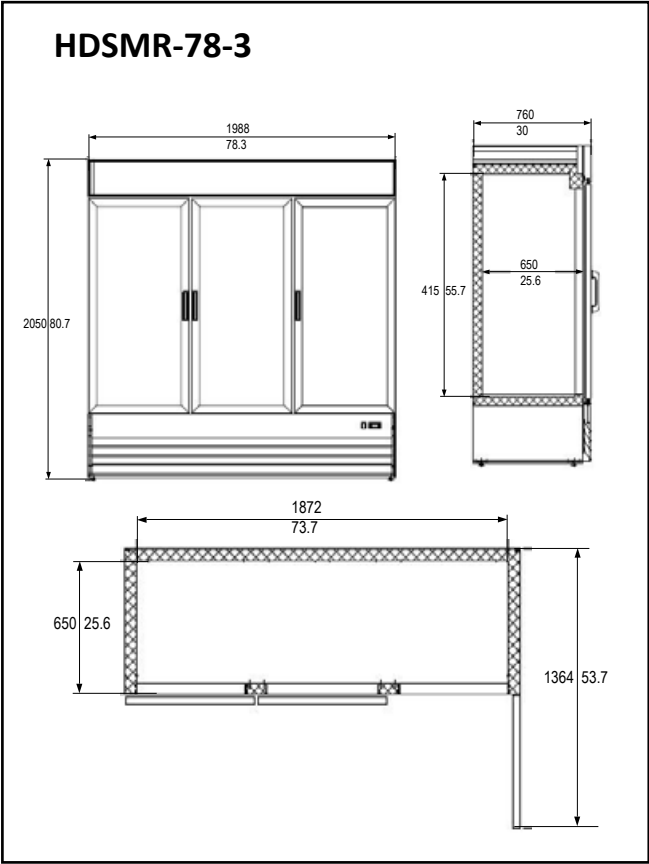
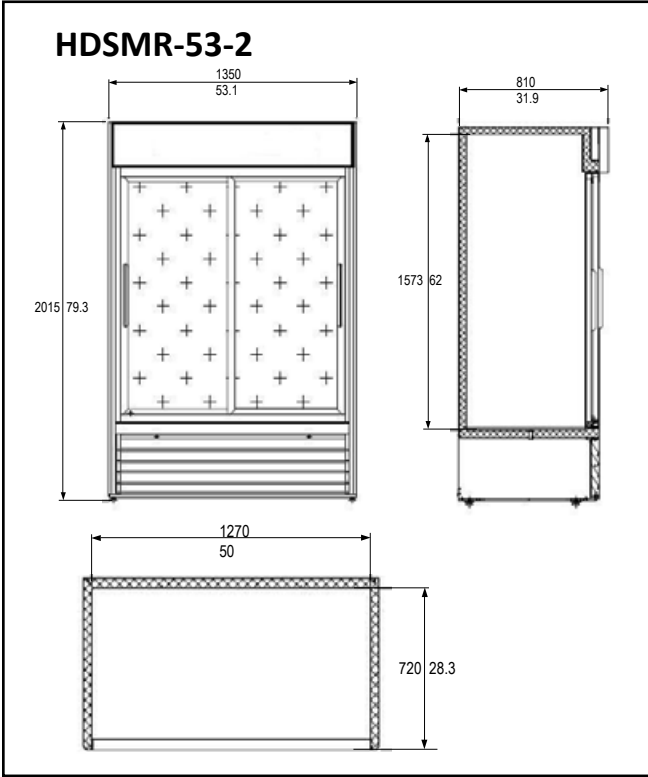
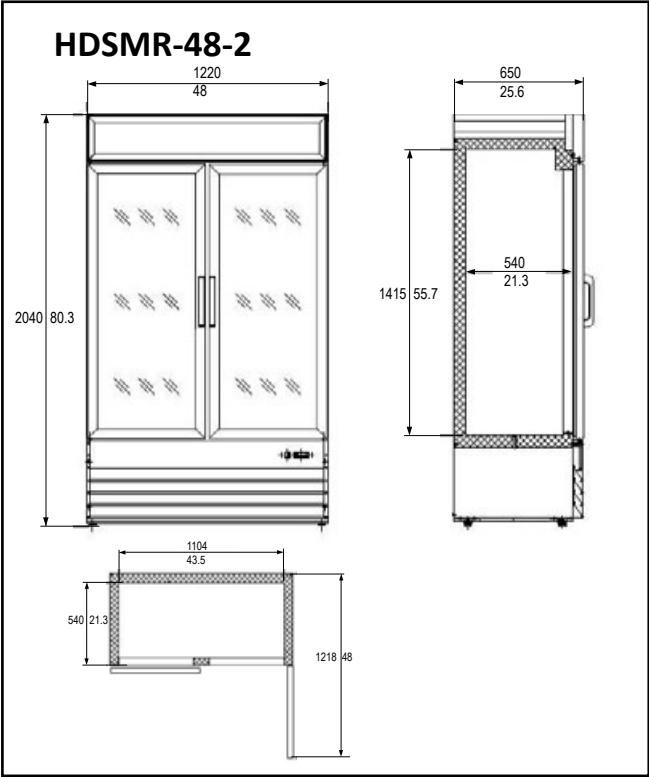



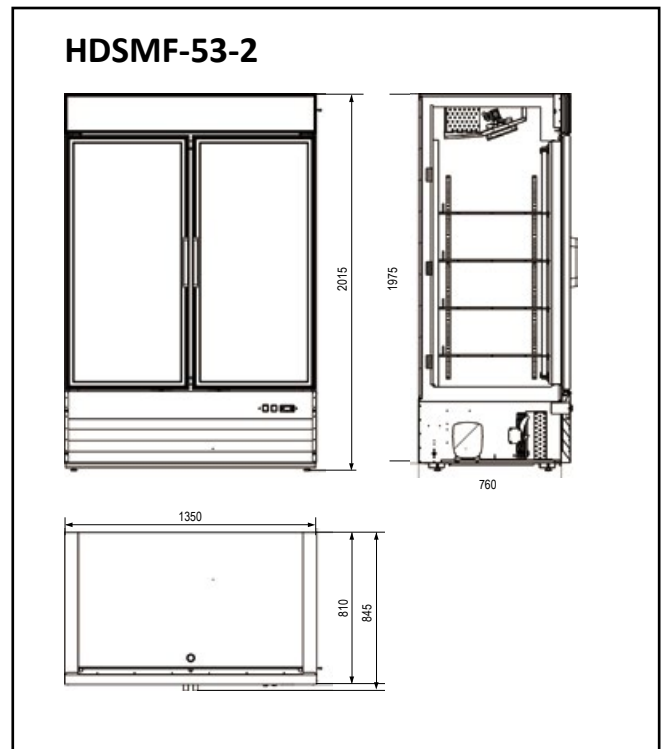
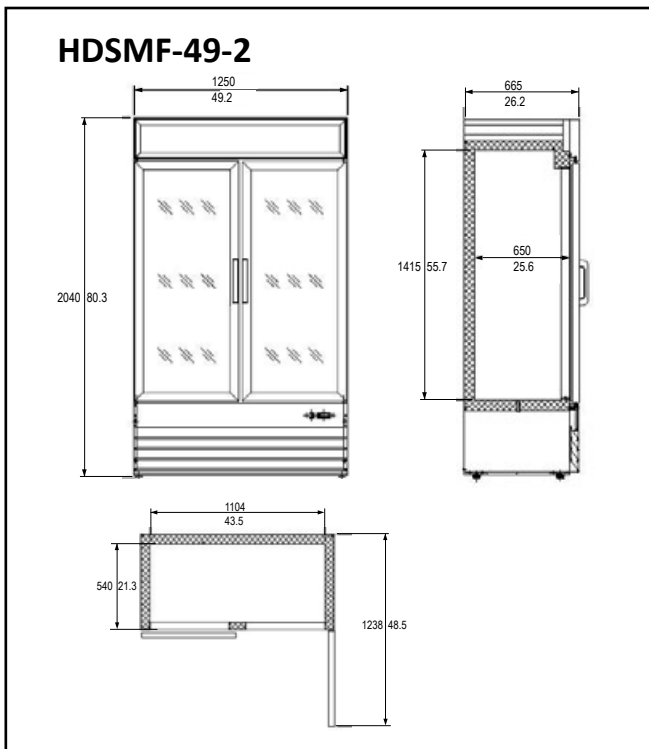
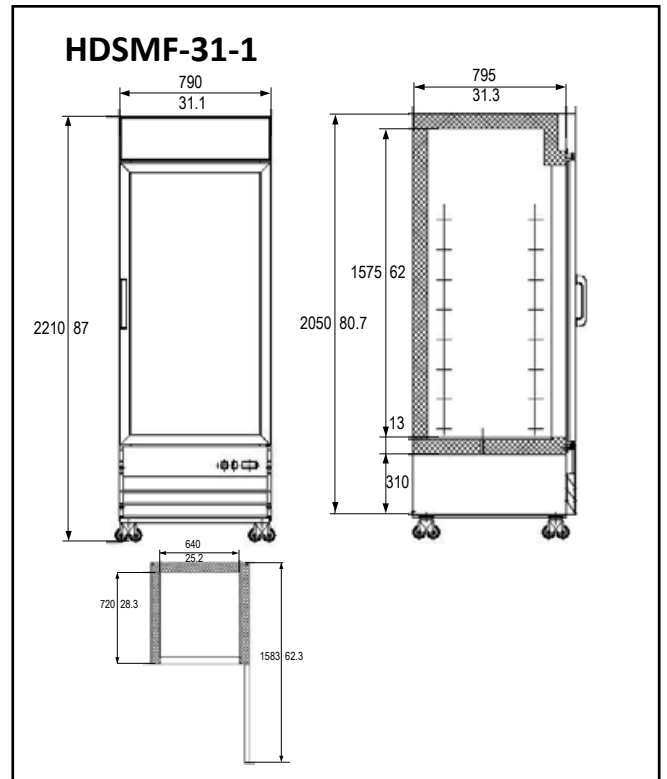
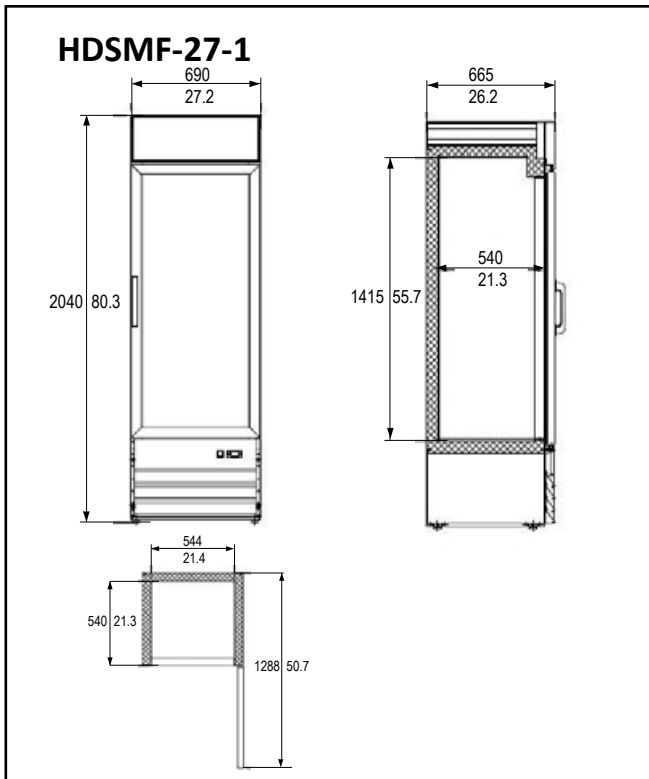

# Plan View

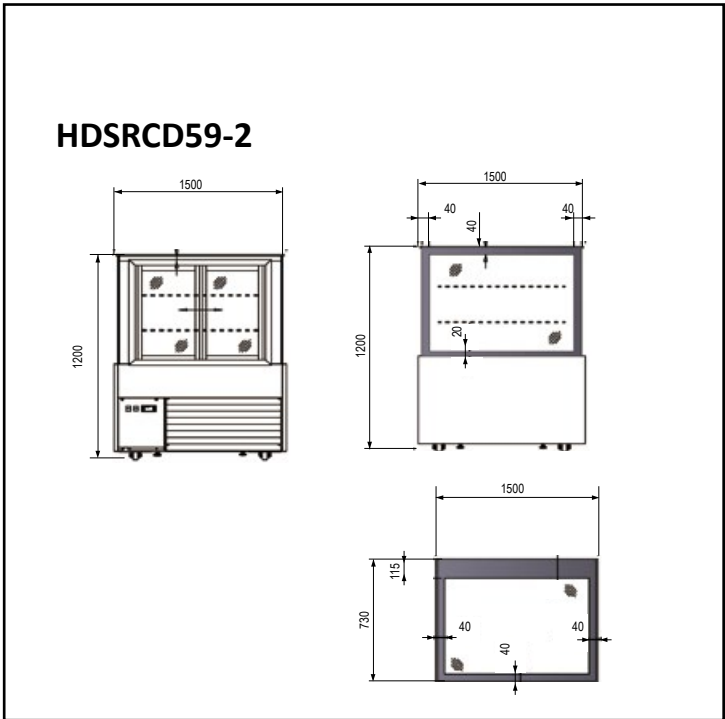
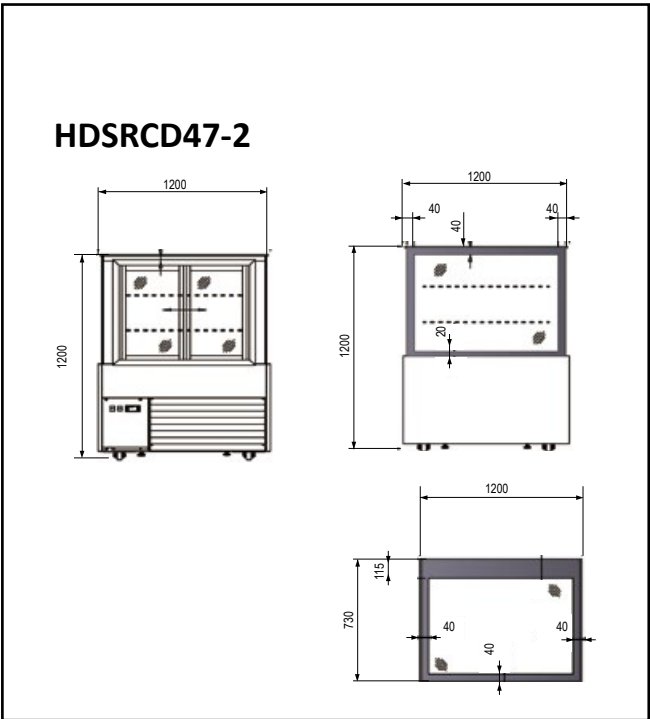
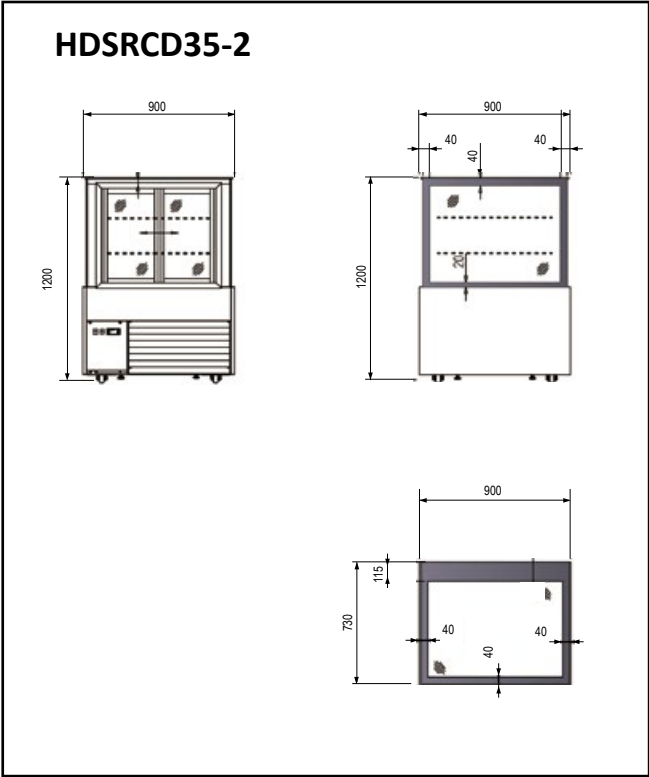
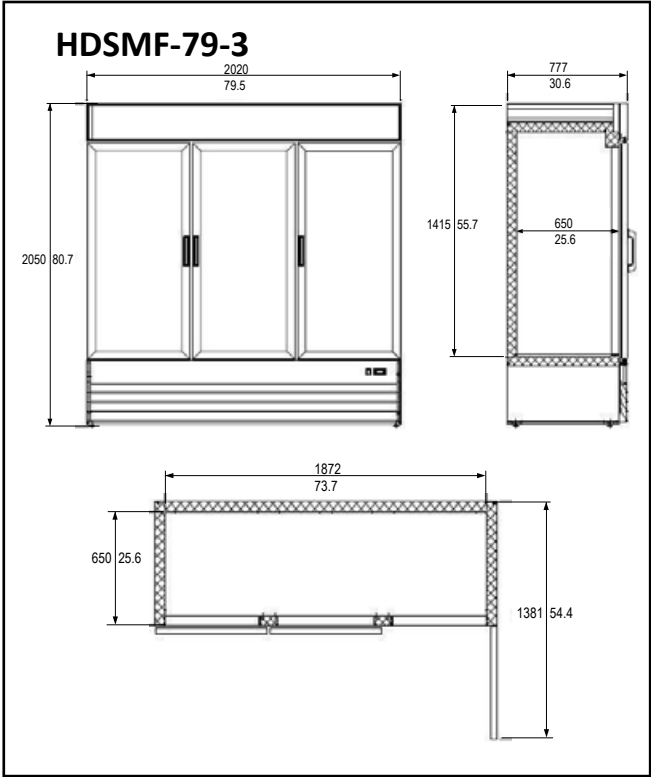

### HDSRCD70-2

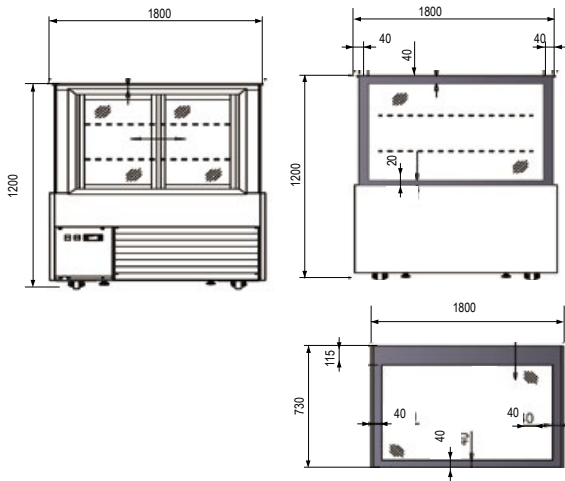

### HDSRCD35-3

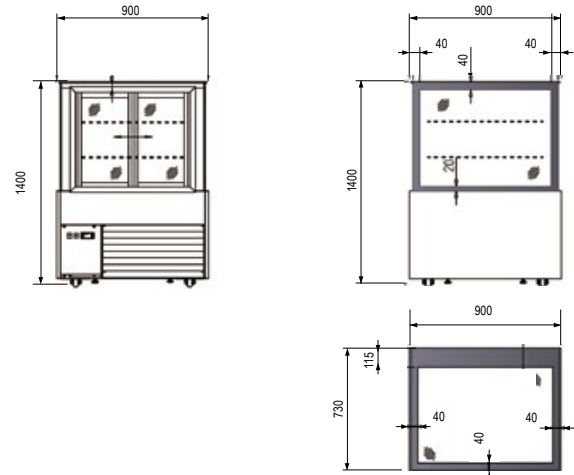

### HDSRCD47-3

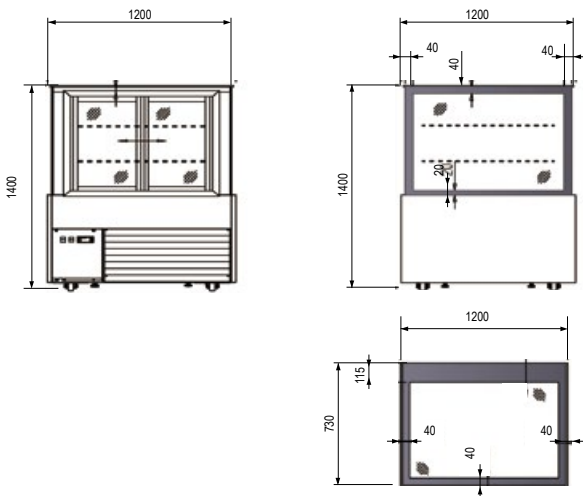

### HDSRCD59-3

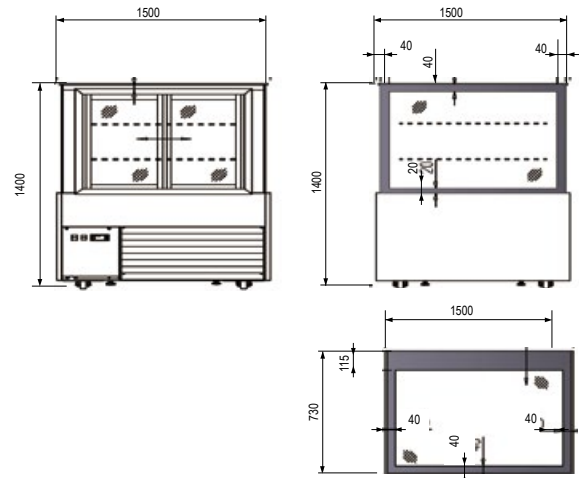

### HDSRCD70-3

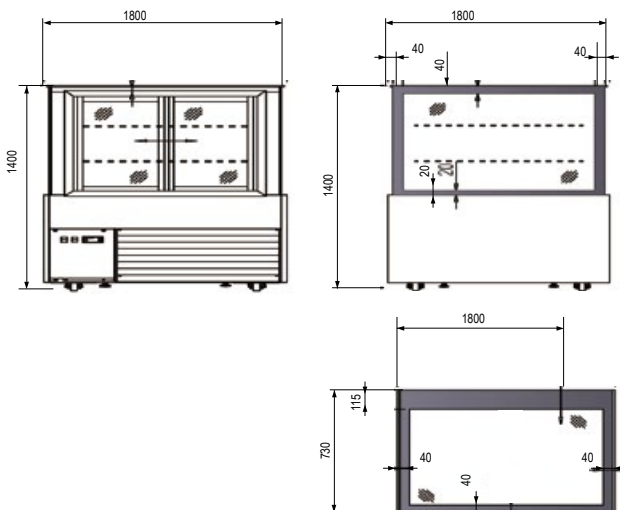

### HDSMC-34

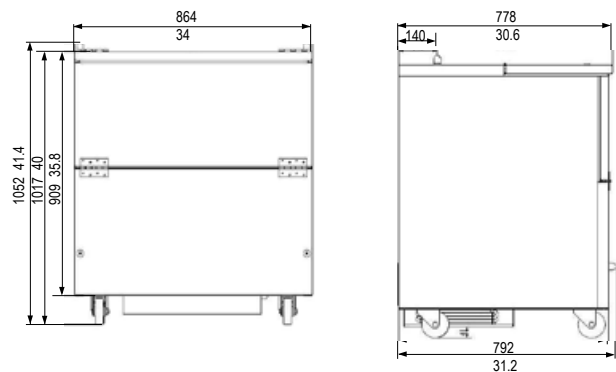

# Plan View

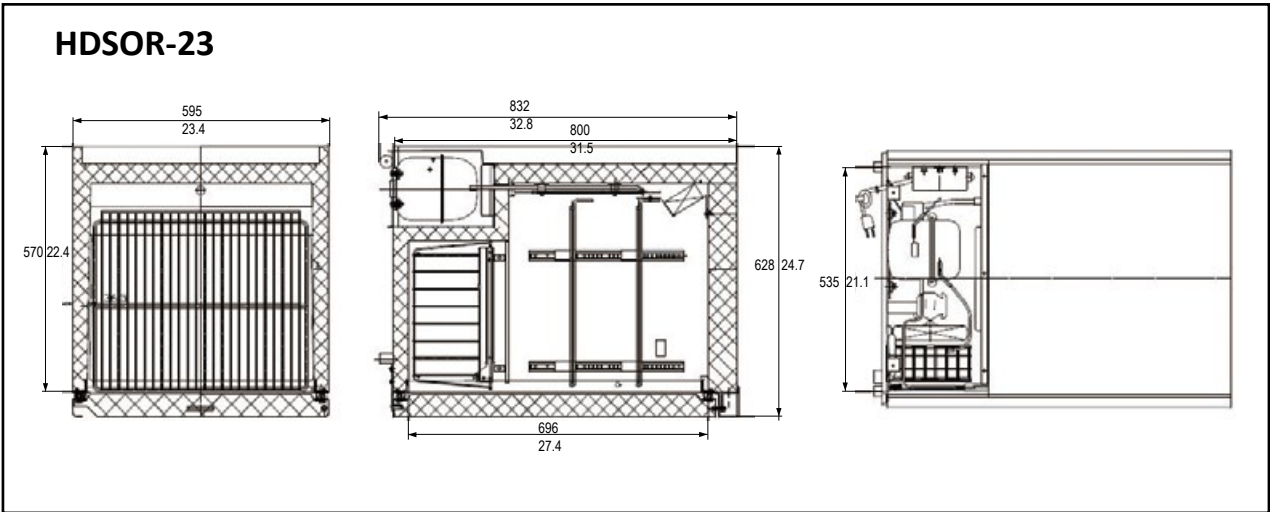
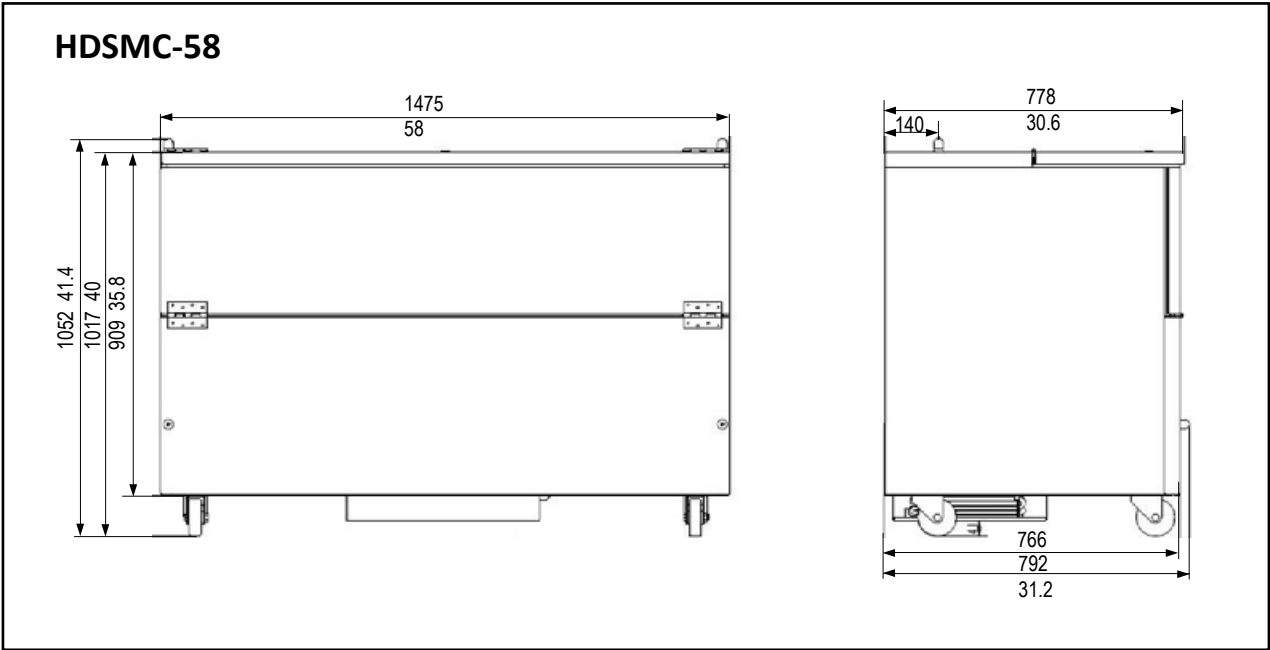
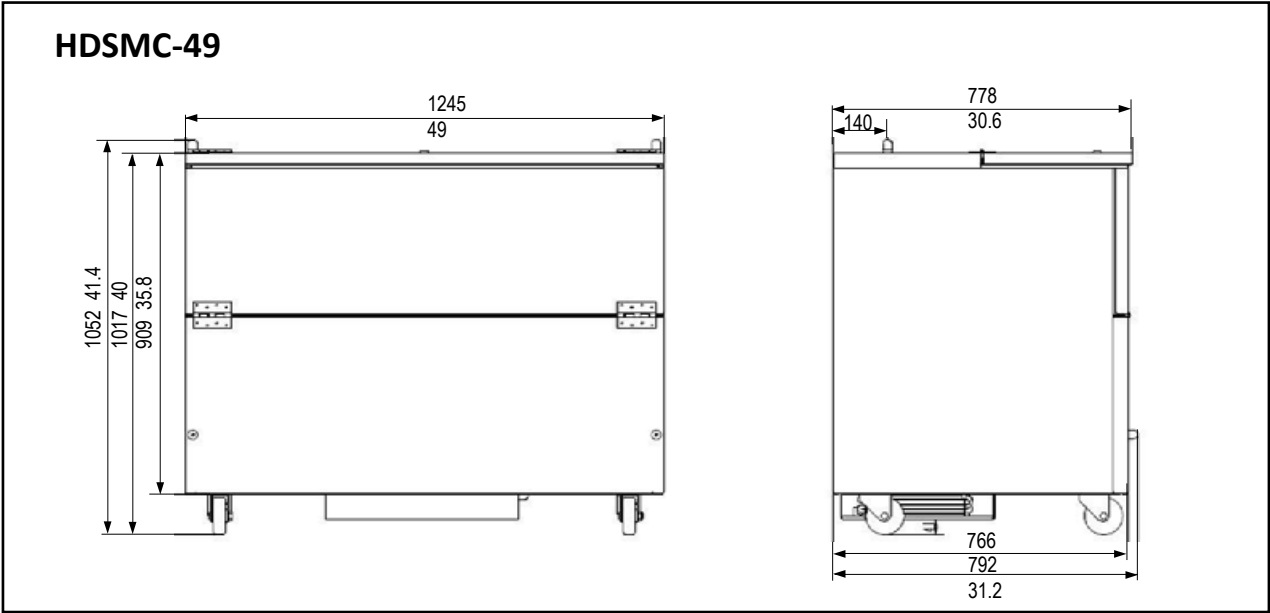

### HDSBB-30-23S

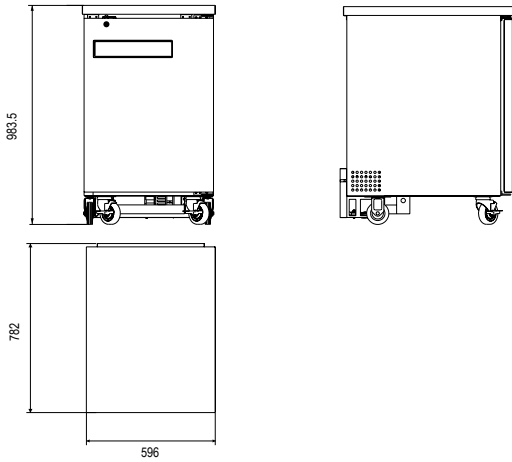

### HDSBB-30-23G

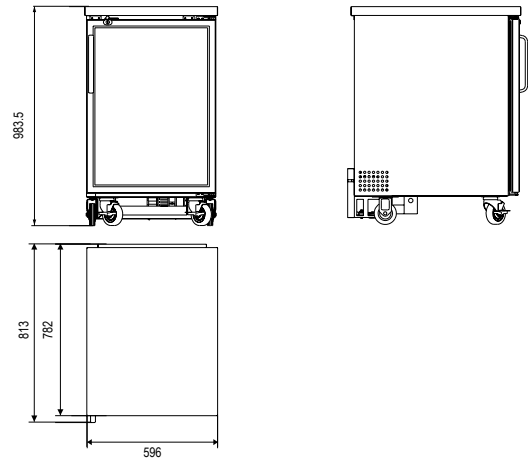

### HDSBB-27-58S

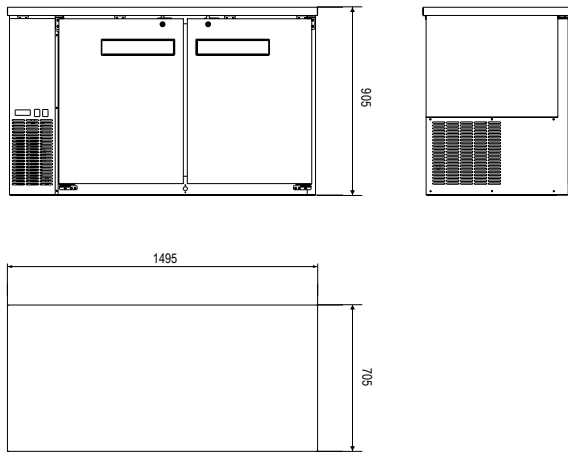

### HDSBB-27-58G

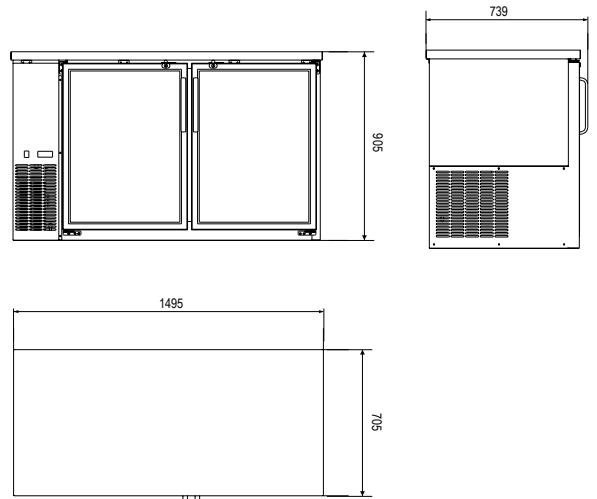

### HDSBB-27-69S

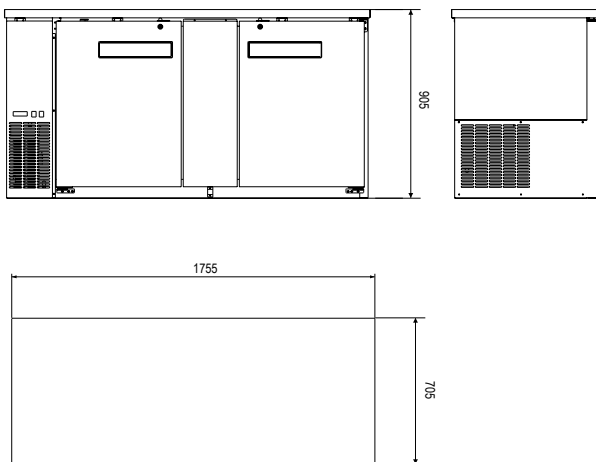

### HDSBB-27-69G

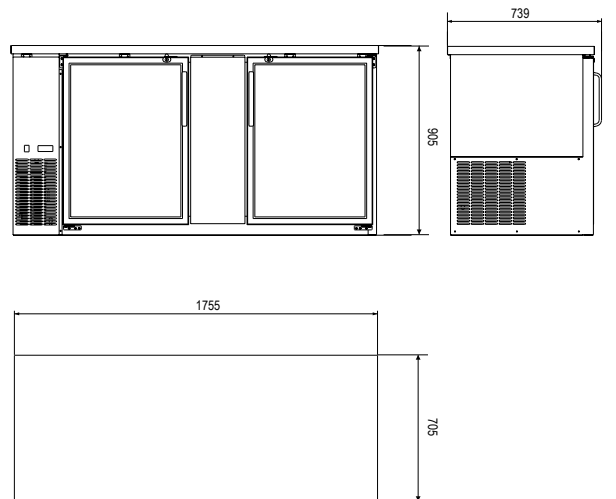

# Plan View

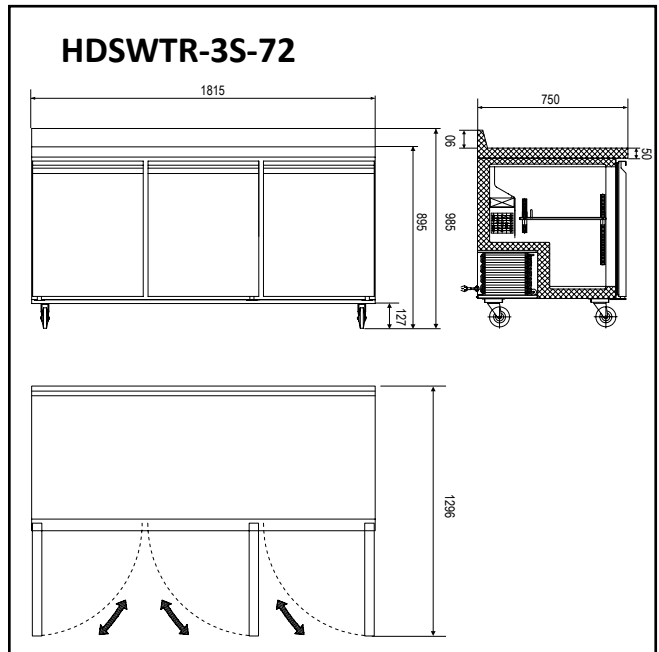
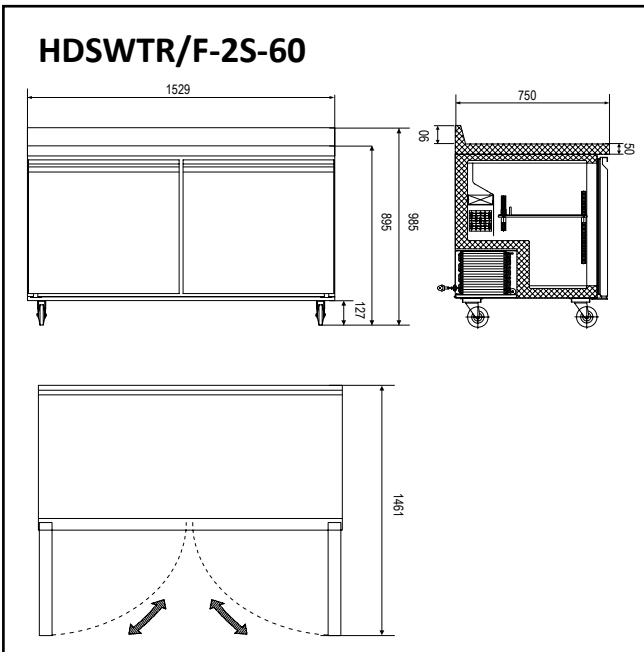
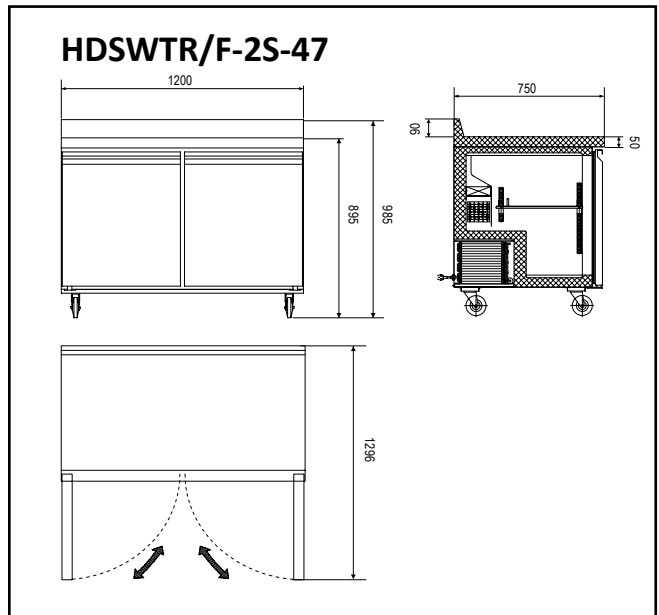
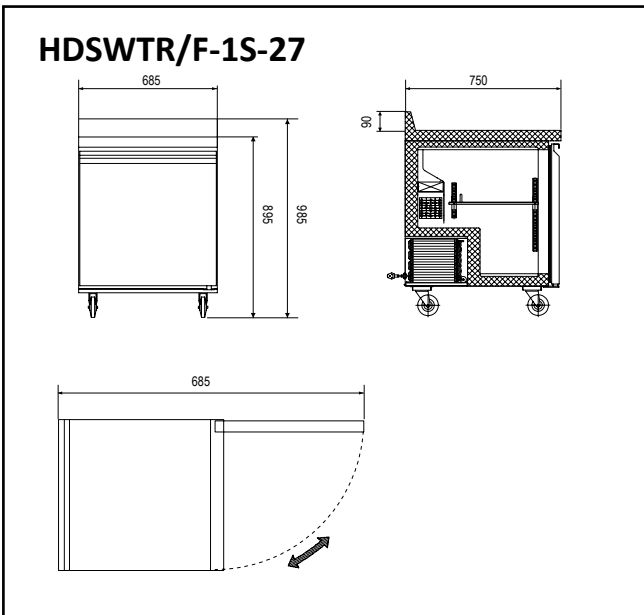
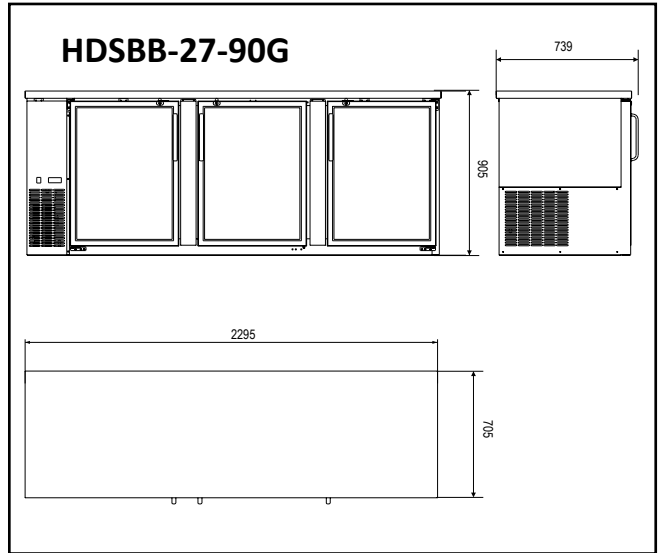
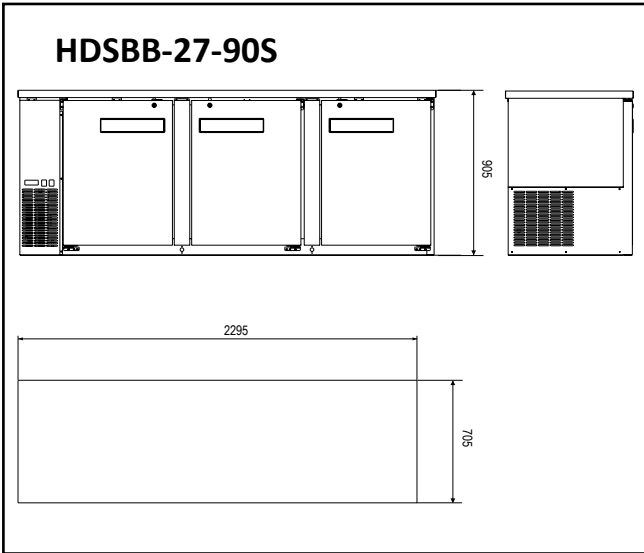

### HDSRDC-36

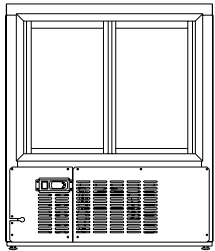
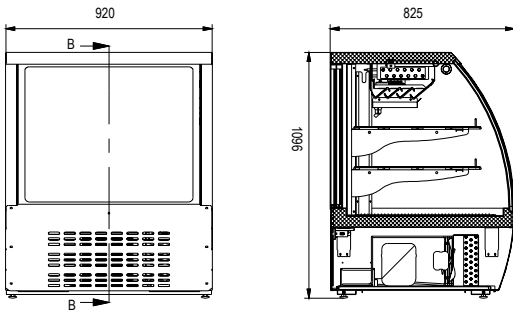

### HDSRDC-64

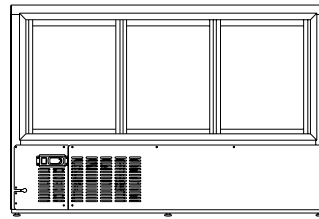
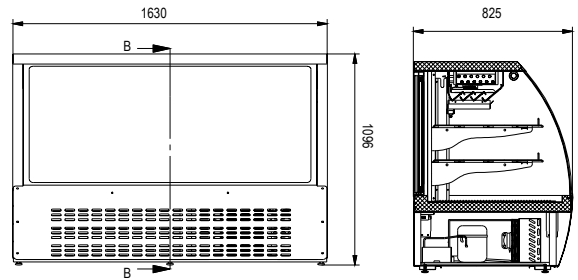

### HDSRBC-50

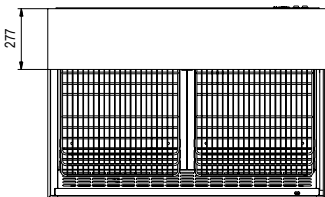
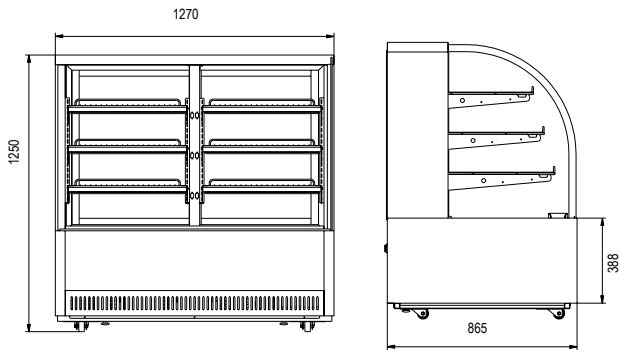

### HDSRBC-59

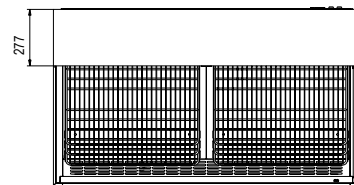
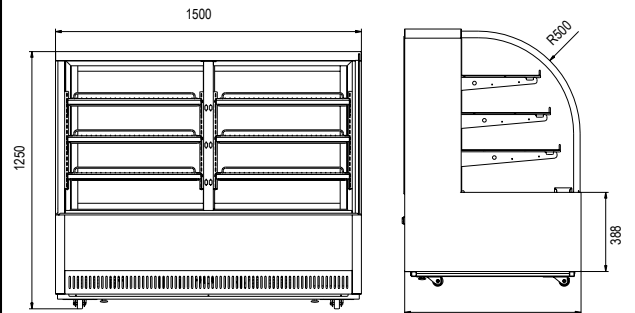

# Plan View

## HSDPC-47

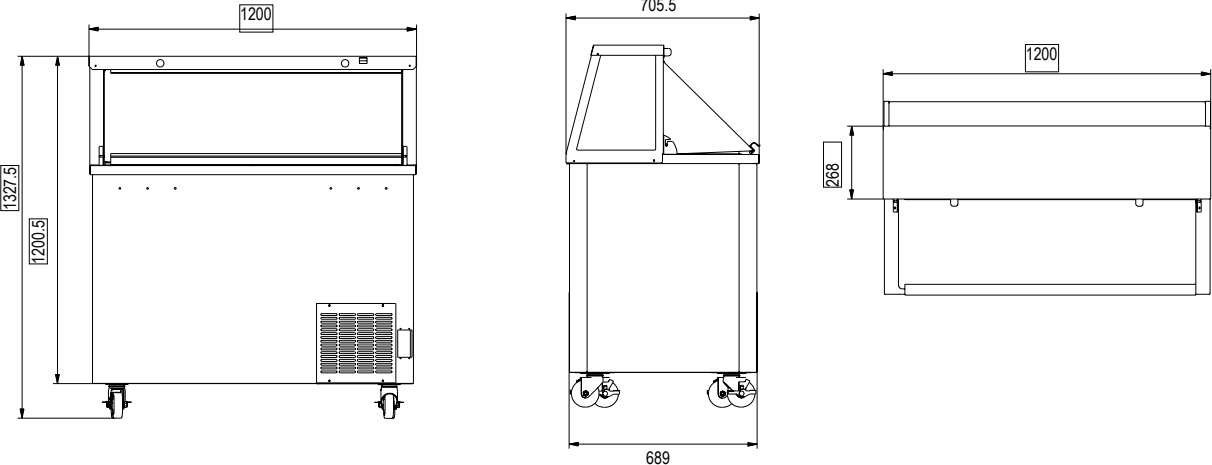

## HSDPC-68

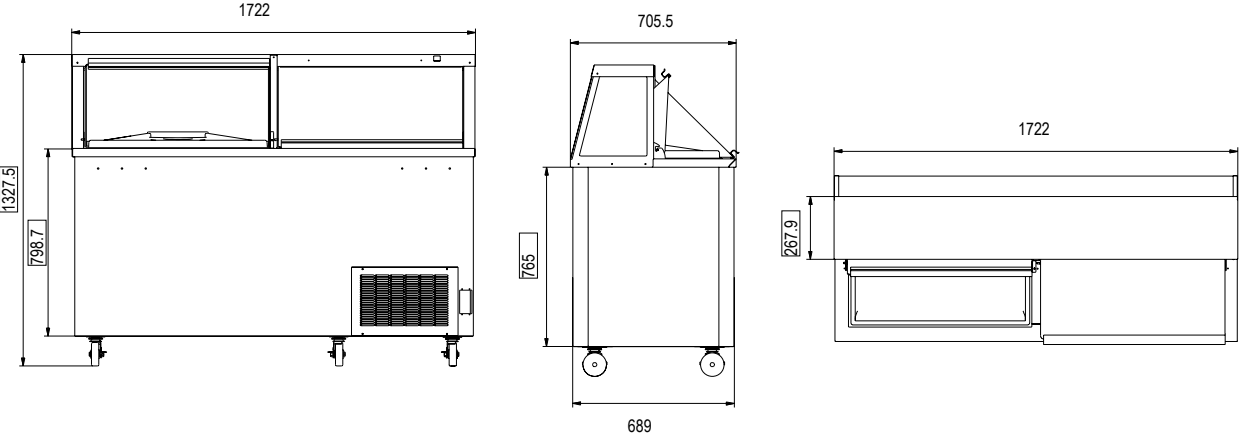



### HDSRCM-24

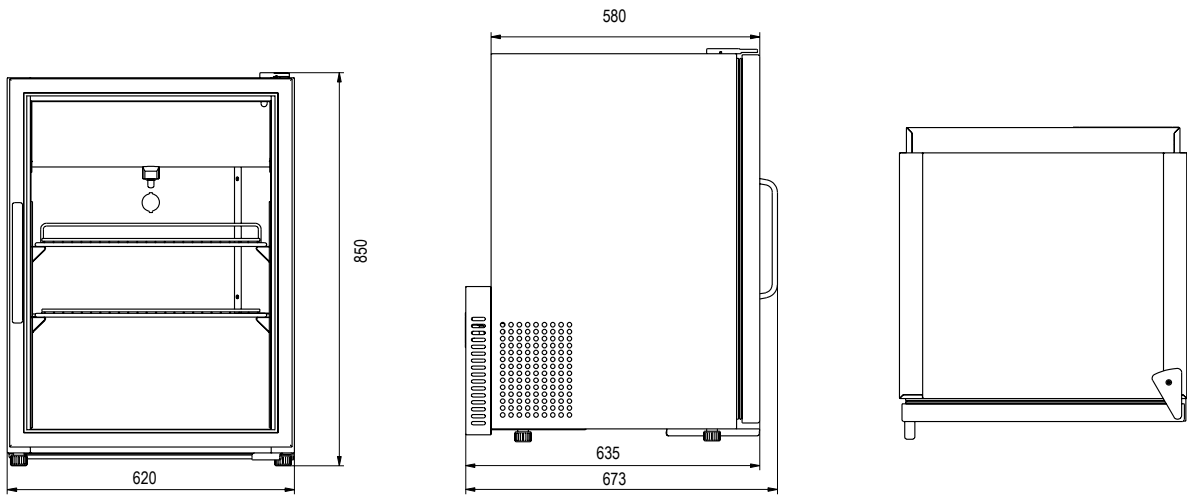

### HDSRCM-24H

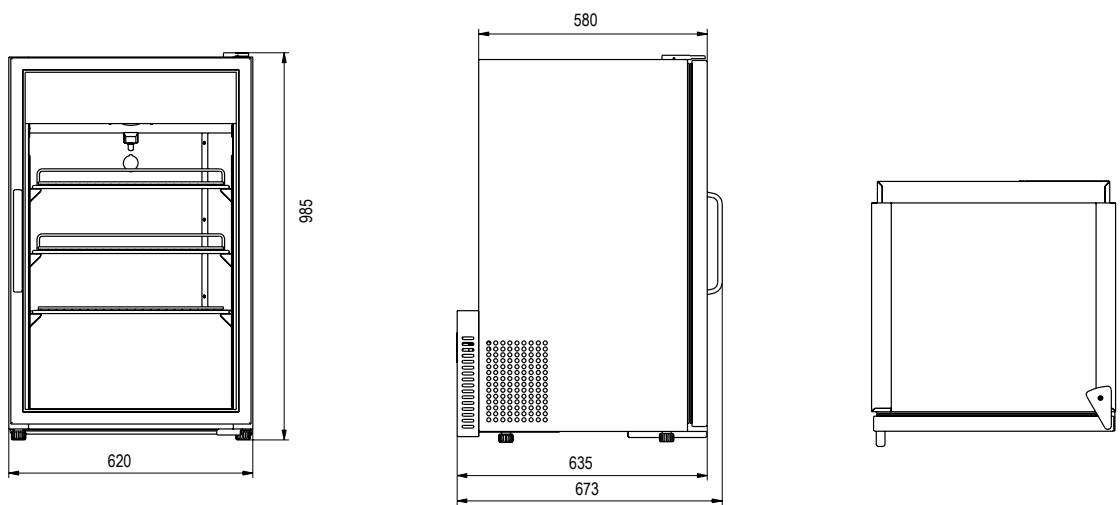



HEAVY DUTY SYSTEMS

Add : 143 West 29th Street, New York, NY 10001

Tel : 212.924.6920

Fax : 212.627.1759

E-mail : [sales@heavydutysys.com](mailto:sales@heavydutysys.com)